

BASIC ELECTRICAL ENGINEERING

UNIT -1

DC CIRCUITS

Vibha Masti

Feedback/corrections: vibha@pesu.pes.edu

Books

Textbook: Electrical and Electronic Technology - E Hughes

Ref book: D.C. Kulashrestha or V.N. Mittal (Basic Electrical Engineering)

Definitions

Direct current

- unidirectional
- V, I, P constant (magnitude)
- we observe responses in circuit (V, I, P)
- frequency 0

Circuit

- closed path for current to flow in
- connection of many electrical elements

Electrical elements

Active elements:

- give energy to do work
- source, generator, dynamo

Passive elements

- use energy
- resistor (dissipating element), inductor (storing), capacitor (storing)
- L & C not active, but may seem to act like

Voltage

- potential difference between A and B
- work done in bringing unit charge from A to B
- units: Voltage (V)
- units are very important
- symbol: V

Current

- rate of flow of charge
- units: Ampere (A)
- symbol: I

Resistance

- opposition to the flow of current
- units: Ohms (Ω)
- symbol: R

OHM'S LAW

Potential difference between two points of a circuit is directly proportional to the current flowing through the circuit

$$V = IR$$

Source (DC)

- all electrical/electronic circuits require a source
- current source, voltage source
- independent source, dependent source

Voltage source

- provides prescribed PD
- V will not vary

Ideal source

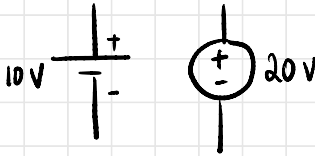

Practical source

- resistance in series
- negligible

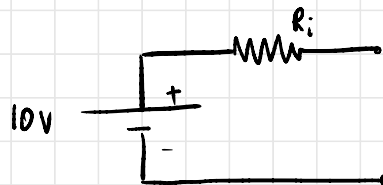

Current Source

- Also a voltage source that maintains a constant current

Ideal source

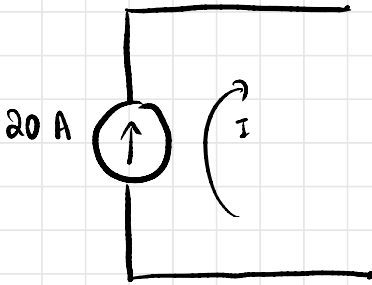

Practical source

- high R_i in parallel
- R_i very high

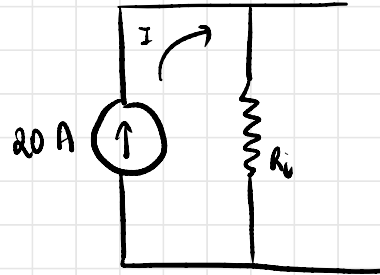

Note: Internal Resistance

In order to protect devices in short circuit and open circuit conditions, internal resistance is added.

* What is mesh?

TYPES OF CONNECTIONS

1. Series] min 2 points
2. Parallel] min 2 points
3. Star] min 3 points
4. Delta] min 3 points

Network

- does not necessarily have current / function
- simply connections of electrical elements
- circuit: current must flow / function must be present

Branch

- part of a network / circuit between any 2 points (nodes / junctions)

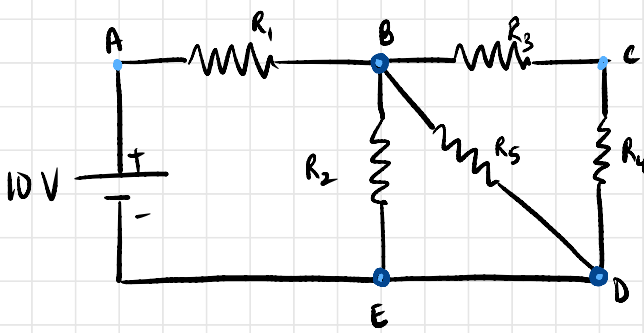

Node •

connection between 2 elements

Junction ○

where current splits

Loop

closed path for current to flow

Mesh

- loop that contains no other loops
- BDEB is mesh, BCDEB not
- smallest loops in a circuit

07.01.2020

OPEN CIRCUIT & SHORT CIRCUIT

Open Circuit

- Break in a circuit

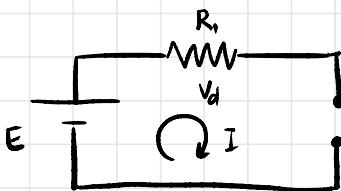

$$I = 0$$

$$V = E (\infty)$$

$$R = \infty$$

Short Circuit

- Two nodes made equipotentials
- Momentary current very high
- Damages circuit

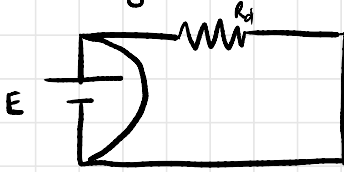

$$I = \infty$$
$$V = 0$$
$$R = 0$$

1) SERIES CONNECTION

- When the current through all the elements (resistances) is the same
- The voltages across all elements will differ

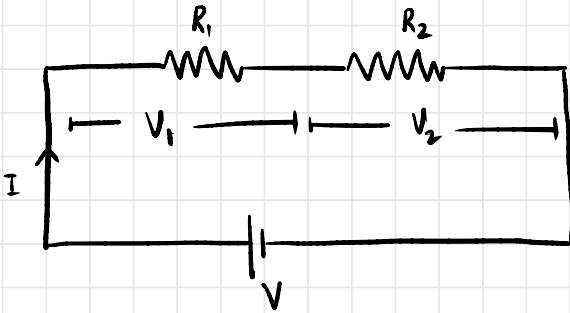

Voltage Division Rule

$$V = V_1 + V_2$$
$$V = IR_1 + IR_2 = I(R_1 + R_2)$$

$$V = \frac{V_1}{R_1} (R_1 + R_2)$$

$$V_1 = \frac{V R_1}{R_1 + R_2}$$

2) PARALLEL CONNECTION

- When the voltage across the elements is the same
- The current flowing through will be different.

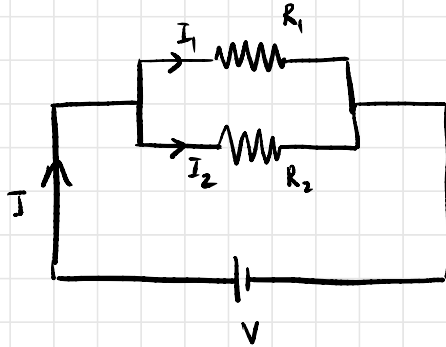

Current Division Rule

$$I = I_1 + I_2$$

$$I = \frac{V}{R_1} + \frac{V}{R_2} = V \left(\frac{1}{R_1} + \frac{1}{R_2} \right)$$

$$I = I_1 R_1 \left(\frac{1}{R_1} + \frac{1}{R_2} \right) = I_1 R_1 \left(\frac{R_1 + R_2}{R_1 R_2} \right)$$

$$I_1 = \frac{I R_2}{R_1 + R_2}$$

Problems

Q1. Find the supply voltage V in the given circuit

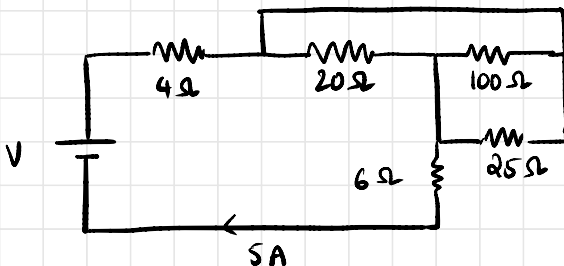

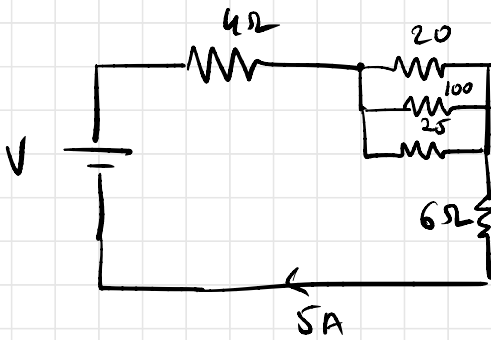

$$R_{eq} = 20 \Omega$$

$$V = 100 \text{ V}$$

Q2. Find resistance between A and B

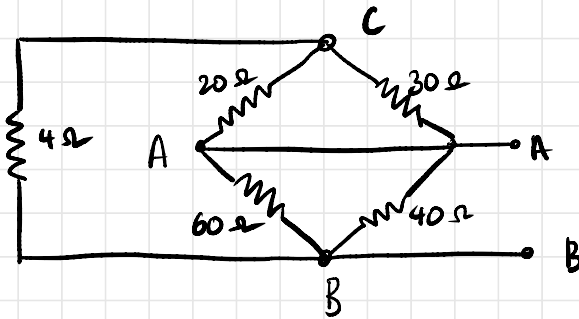

$$R_{eq} = 9.6 \Omega$$

$$AC : 12 \Omega = 16 \Omega \quad AB \parallel 40 \parallel 60$$

$$CB : 4 \Omega$$

Q3. Find the value of voltage V such that 2A of current is flowing through 6Ω

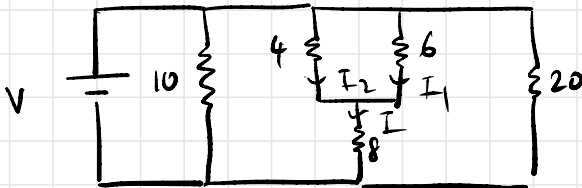

$$R_{eq} = \frac{65}{16}$$

$$I_1 = 2A = \frac{IR_2}{R_1 + R_2} = \frac{I(4)}{(10)} = 0.4I$$

$$I = 5A$$

$$V = 5\left(\frac{52}{5}\right) = 52V$$

Q4. Find R_{AB}

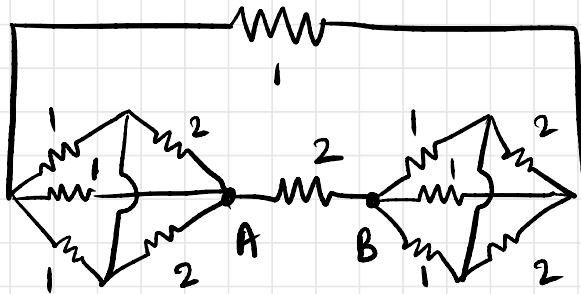

$R_{AB} = ?$

$$R_{AB} = \frac{22}{21} = 1.047\Omega$$

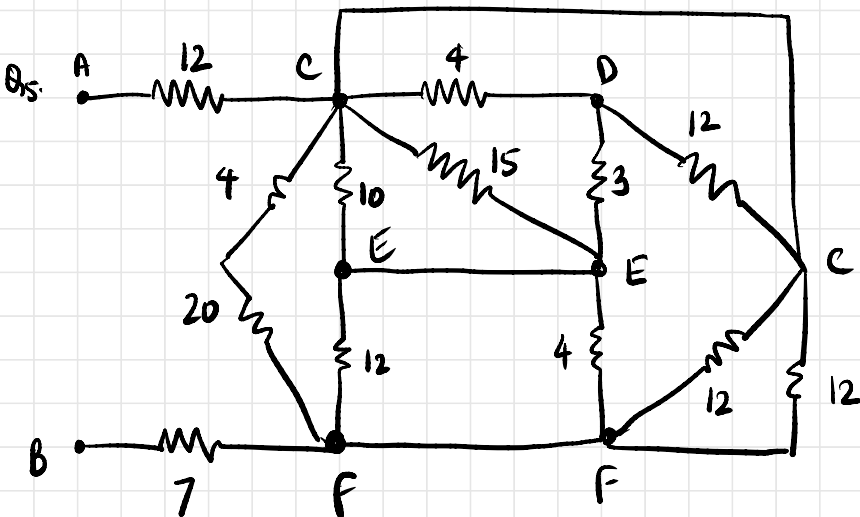

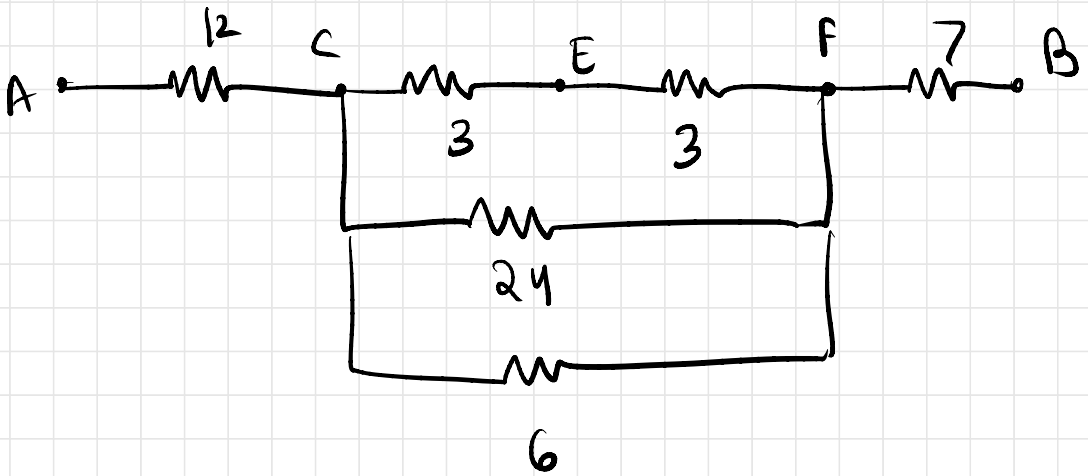
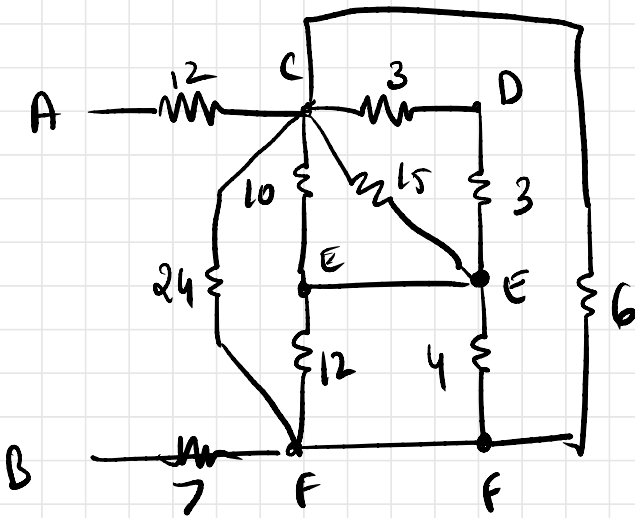

$$R_{AB} = \frac{65}{3} = 21.6667$$

4

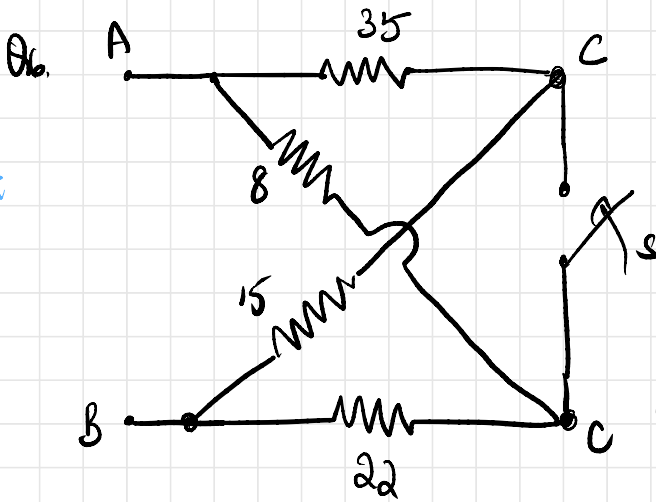

(i) For the circuit shown, find V_{AB} and voltage across 8Ω if switch S is open if V across 15Ω is $45V$

(ii) Find R_{AB} if S is closed

(i) in open circuit, $V_{BC} = 45V, R = 15$
 $I = 3A$

$$V_{AB} = 150V$$

$$\therefore V_{AC} = 3 \times 35 = 105V$$

$$150 = I_2(30) \Rightarrow I_2 = 5A, \quad V_{8\Omega} = 40V$$

(ii) if S closed,

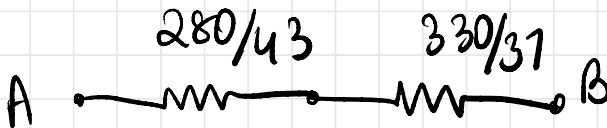
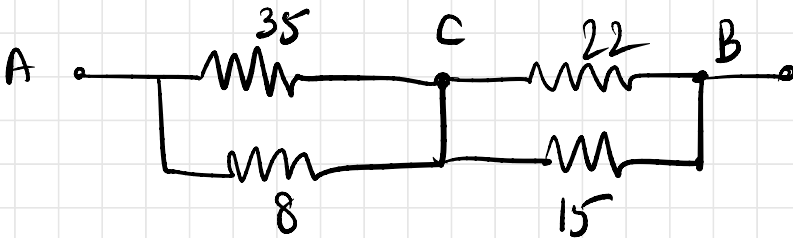

$$R_{AB} = 15.43\Omega$$

Q7.

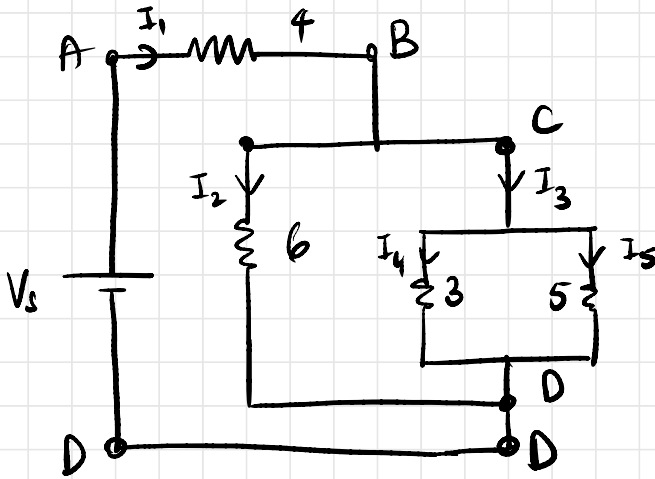

If $I_4 = 4A$, find I_1, I_2, I_3, I_5

$$(3)(4) = 5(I_5) \Rightarrow I_5 = 2.4A$$

$$I_3 = I_4 + I_5 = 4 + 2.4 = \boxed{6.4A = I_3}$$

$$R_{35} = \frac{3 \times 5}{8} = \frac{15}{8}, \quad I_3 = 6.4A$$

$$V_{CD} = \frac{15}{8} \times 6.4 = 12V$$

$$12 = 6I_2 \Rightarrow \boxed{I_2 = 2A}$$

$$I_1 = I_2 + I_3 = \boxed{8.4A = I_1}$$

Q8

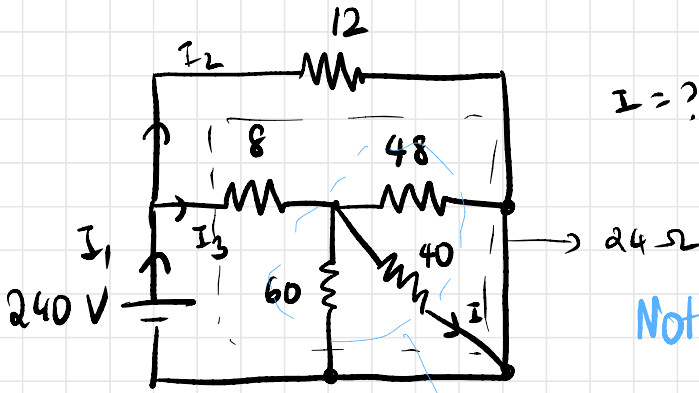

$I = ?$

Note: use VDL to do faster

~~A~~

$$R_{eq} = 8 \Omega$$

$$I_1 = 30 \text{ A}$$

$$I_3 = \frac{I_1(12)}{12+24} = \frac{30}{3} = 10 \text{ A} = I_3$$

$$I_3 = I + I_4$$

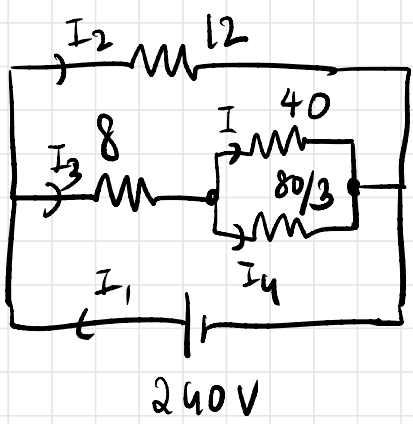

$$I = \frac{\left(\frac{80}{3}\right)(I_3)}{40 + \frac{80}{3}}$$

$$I = 4 \text{ A}$$

Q9.

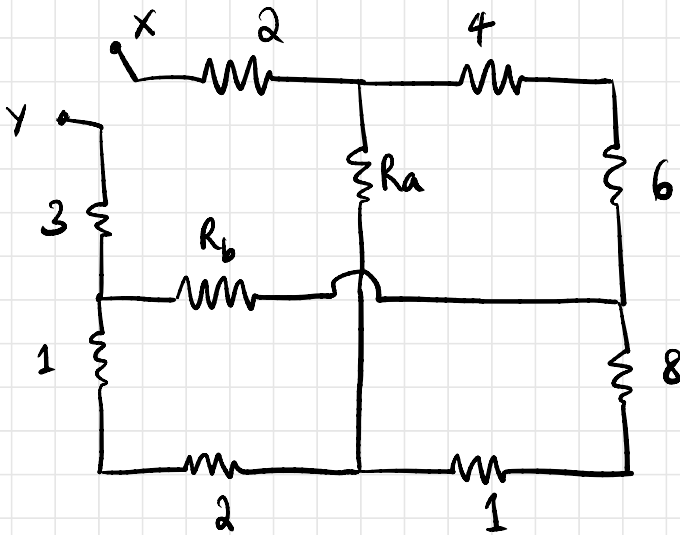

Find R_{xy}

(i) $R_a = R_b = \infty$

(ii) $R_a = 0; R_b = \infty$

(iii) $R_a = \infty; R_b = 0$

(iv) $R_a = R_b = 0$

(i) All in series, $R_{xy} = 27 \Omega$

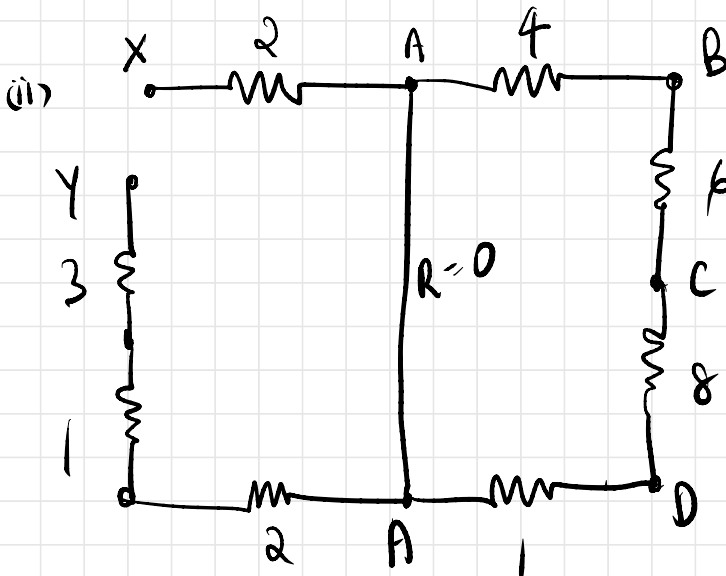

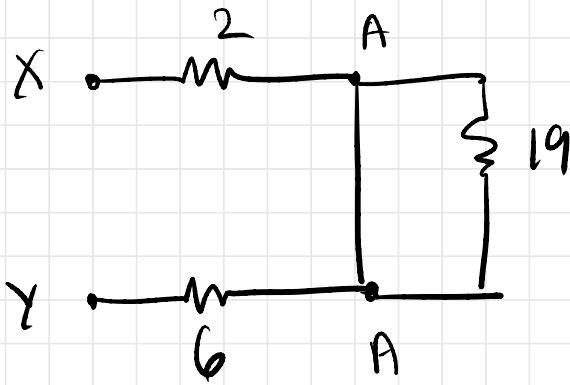

$$R_{xy} = 8 \Omega$$

(iii) $R_{xy} = 15 \Omega$

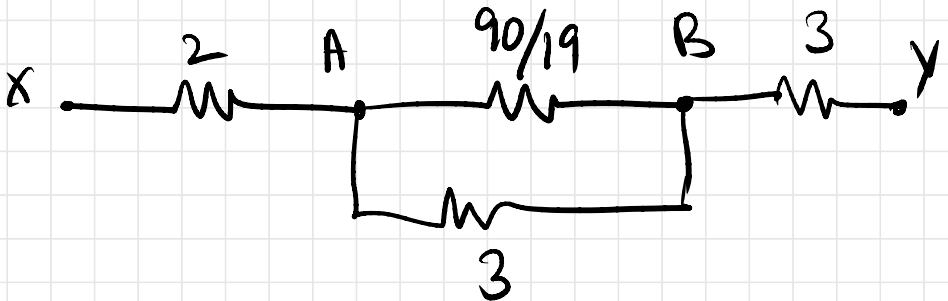
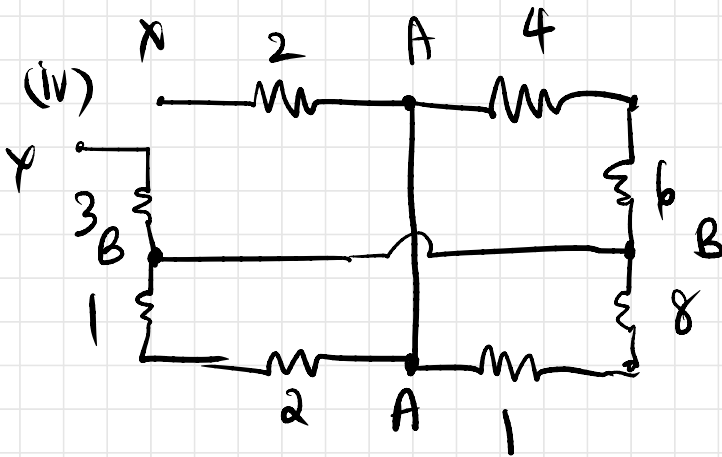

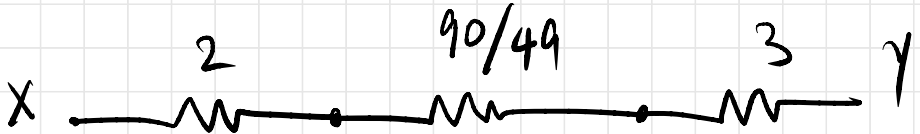

$$R_{xy} = 6.837 \Omega$$

Q10.

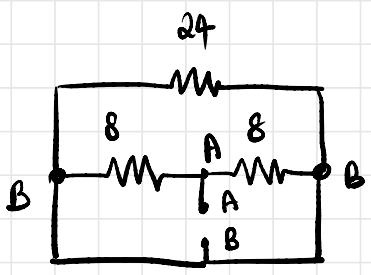

$R_{AB} = 4 \Omega$
 24Ω is shorted

10.01.2020

3) STAR CONNECTION

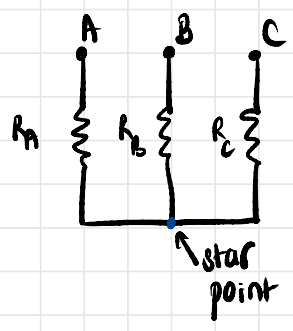

OR

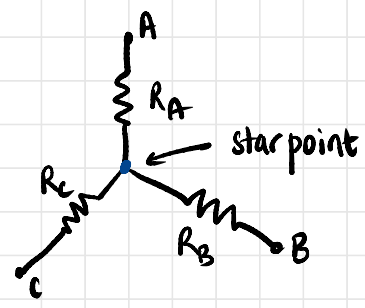

• also called WYE (Y)

4) DELTA CONNECTION

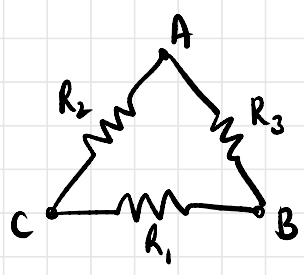

also called MESH (Δ)

DELTA-STAR TRANSFORMATION

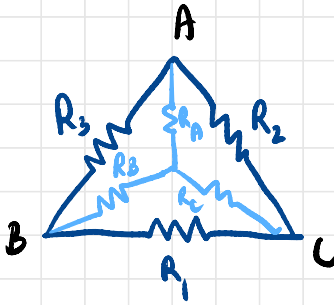

1) eliminating node A

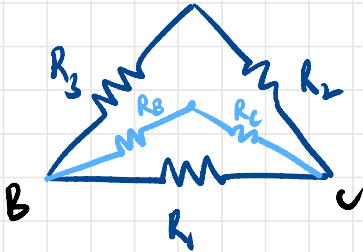

equating star & delta resistances

$$R_B + R_C = \frac{(R_1)(R_2 + R_3)}{R_1 + R_2 + R_3} \rightarrow (1)$$

2) eliminating node B

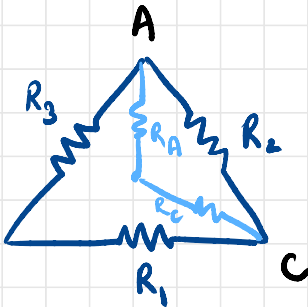

equating star and delta resistances

$$R_A + R_C = \frac{(R_2)(R_1 + R_3)}{R_1 + R_2 + R_3} \rightarrow (2)$$

3) Eliminating node C

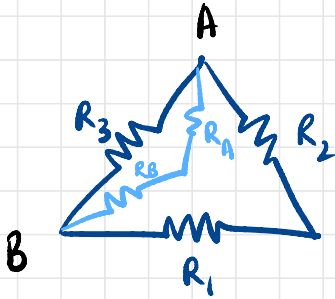

equating star & delta resistances

$$R_A + R_B = \frac{(R_3)(R_1 + R_2)}{R_1 + R_2 + R_3} \quad \text{--- (3)}$$

Adding (1), (2) and (3)

$$R_A + R_B + R_C = \frac{R_1 R_2 + R_2 R_3 + R_3 R_1}{R_1 + R_2 + R_3} \quad \text{--- (4)}$$

Subtracting (1) from (4)

$$R_A = \frac{R_2 R_3}{R_1 + R_2 + R_3} \quad \text{--- (5)}$$

Subtracting (2) from (4)

$$R_B = \frac{R_1 R_3}{R_1 + R_2 + R_3} \quad \text{--- (6)}$$

Subtracting (3) from (4)

$$R_C = \frac{R_1 R_2}{R_1 + R_2 + R_3} \quad \text{--- (7)}$$

To convert

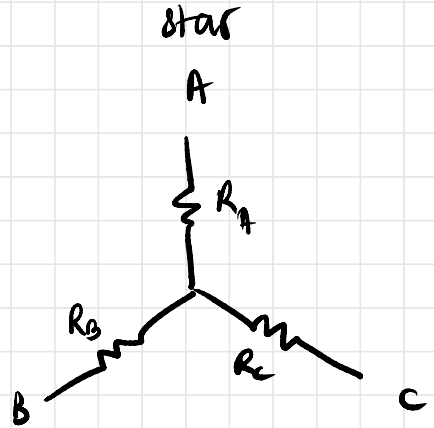
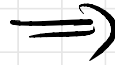
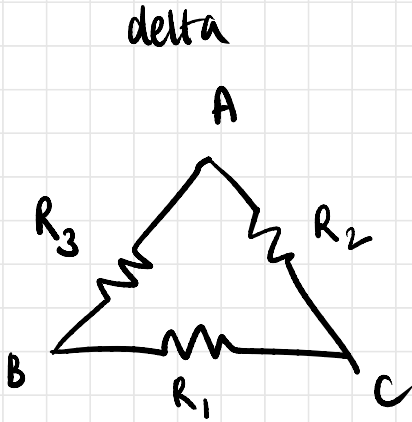

STAR-DELTA TRANSFORMATION

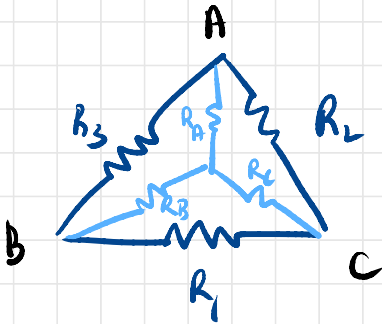

Multiplying (5) and (6)

$$R_A R_B = \frac{R_1 R_2 R_3^2}{(R_1 + R_2 + R_3)^2} \quad \text{--- (8)}$$

Multiplying (6) and (7)

$$R_B R_C = \frac{R_2 R_3 R_1^2}{(R_1 + R_2 + R_3)^2} \quad \text{--- (9)}$$

Multiplying (7) and (5)

$$R_C R_A = \frac{R_1 R_2 R_3^2}{(R_1 + R_2 + R_3)^2} \quad \text{--- (10)}$$

Adding (8), (9) and (10)

$$R_A R_B + R_B R_C + R_C R_A = \frac{R_1 R_2 R_3^2 + R_2 R_3 R_1^2 + R_1 R_3 R_2^2}{(R_1 + R_2 + R_3)^2}$$

$$R_A R_B + R_B R_C + R_C R_A = \frac{R_1 R_2 R_3}{R_1 + R_2 + R_3}$$

i) Taking $R_A = \frac{R_2 R_3}{R_1 + R_2 + R_3}$,

$$R_1 = R_B + R_C + \frac{R_B R_C}{R_A}$$

2) Taking $R_B = \frac{R_1 R_3}{R_1 + R_2 + R_3}$,

$$R_2 = R_A + R_C + \frac{R_A R_C}{R_B}$$

3) Taking $R_C = \frac{R_1 R_2}{R_1 + R_2 + R_3}$,

$$R_3 = R_A + R_B + \frac{R_A R_B}{R_C}$$

To convert

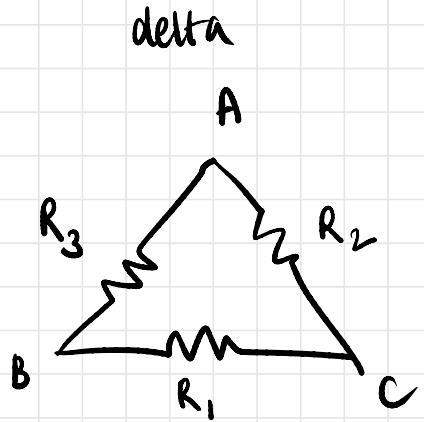
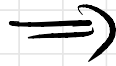
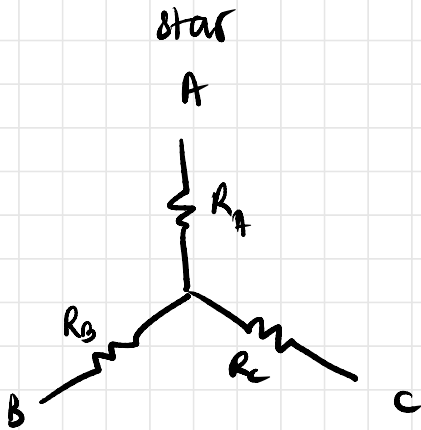

Q11.

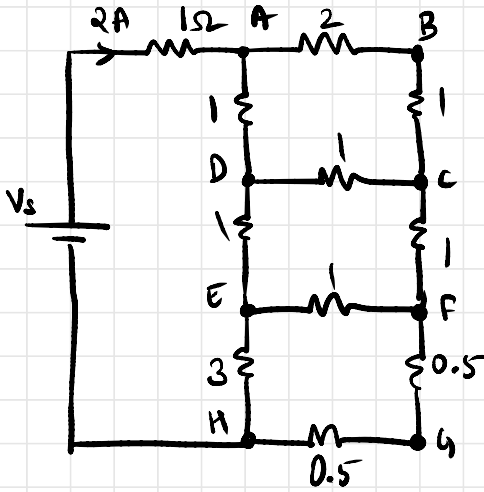

Find V_s that delivers 2A of current to the circuit shown

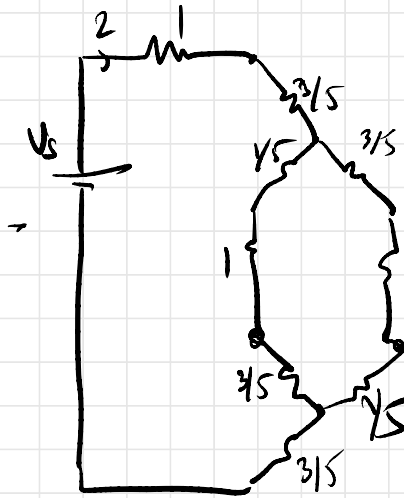
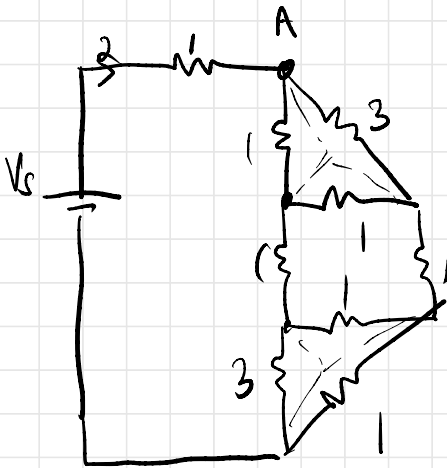

$$R_{eq} = \frac{31}{10}$$

$$V_s = \frac{31}{10} \times 2 = 6.2V$$

Q12.

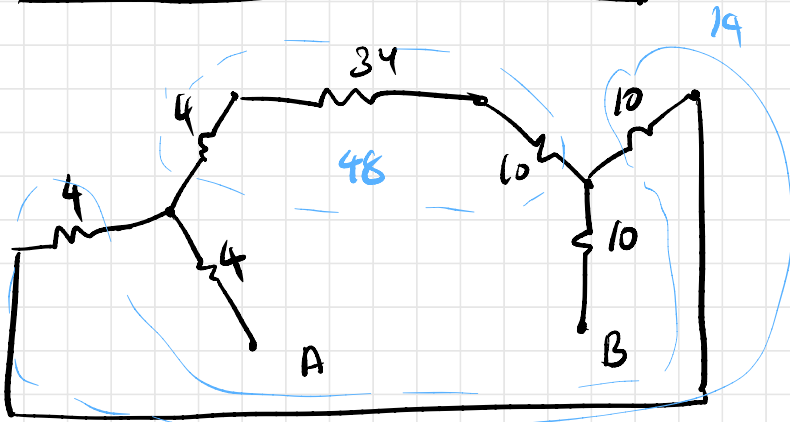
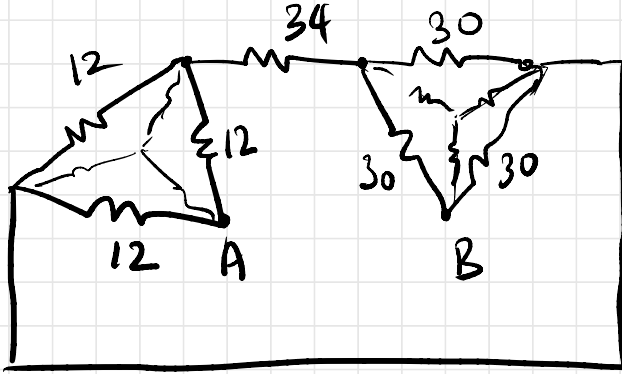
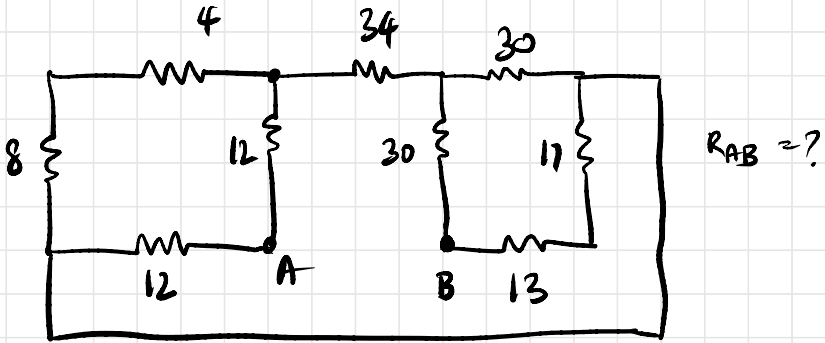

$$R_{AB} = 24.84 \Omega$$

$$52/19$$

$$104/29$$



$$\frac{52}{11}$$

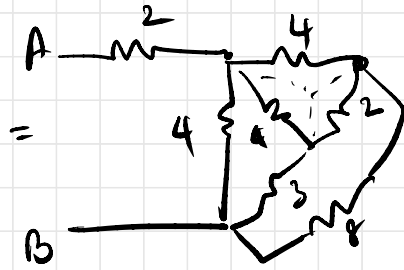
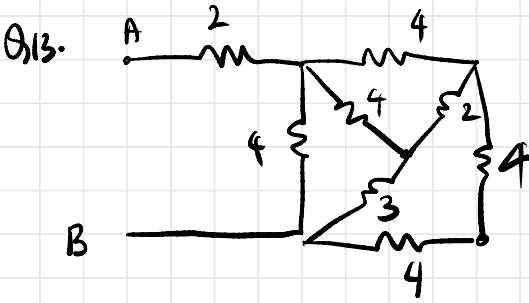

||

$$R_{AB} = 4.06$$

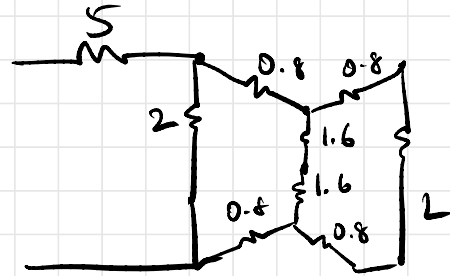
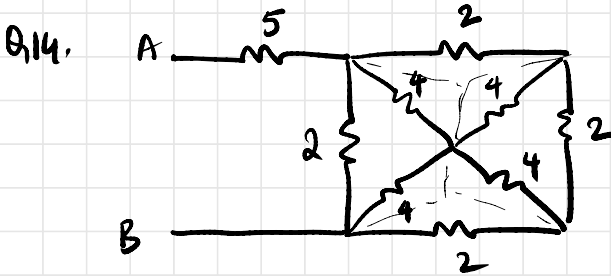
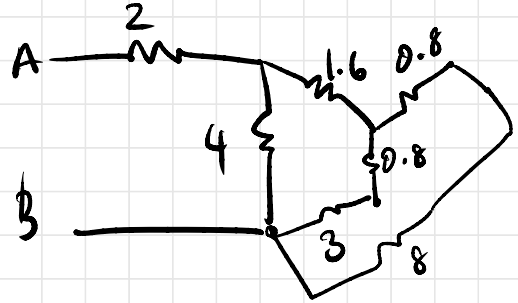

$$R_{AB} = 6.24 \Omega$$

Q15.

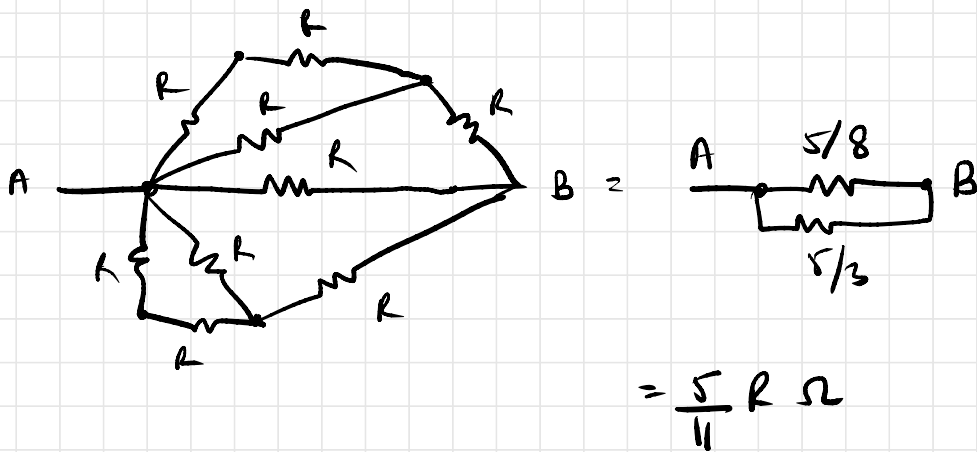

Q16.

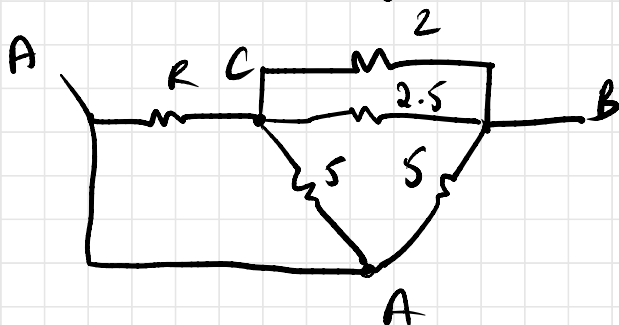
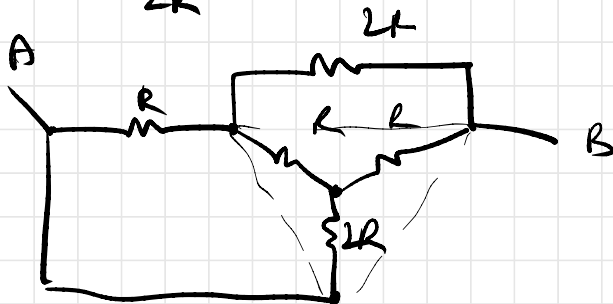
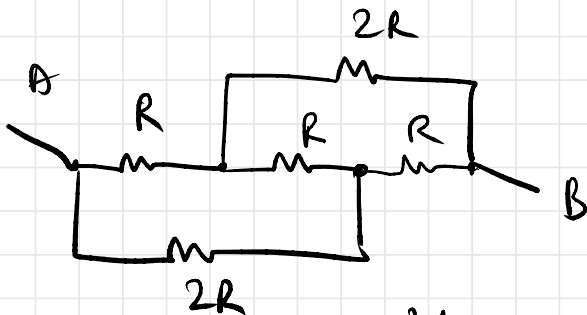

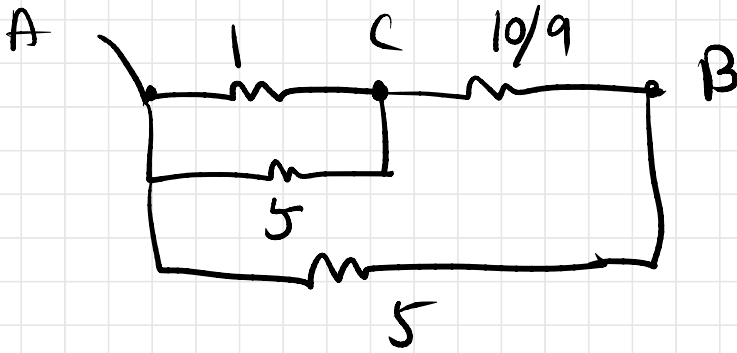

$$R_{AB} = 1.4R$$

Q17.

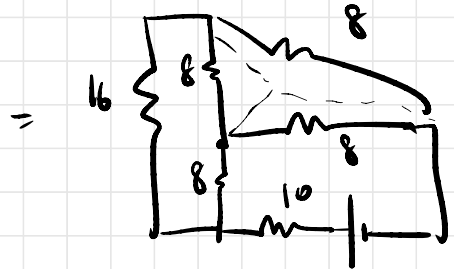
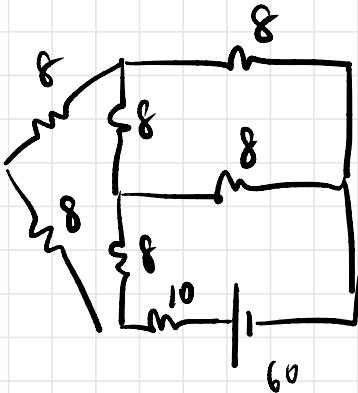
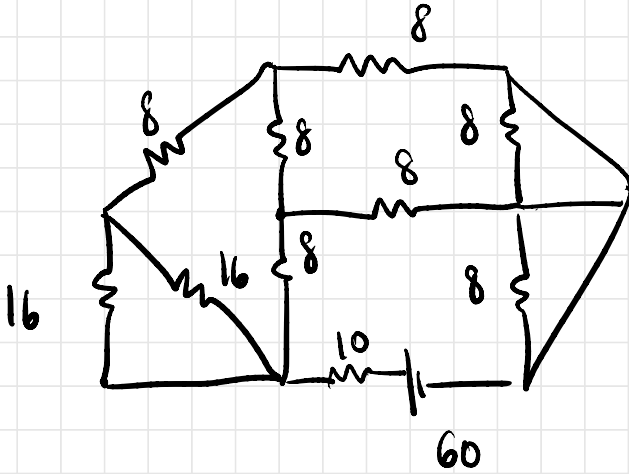

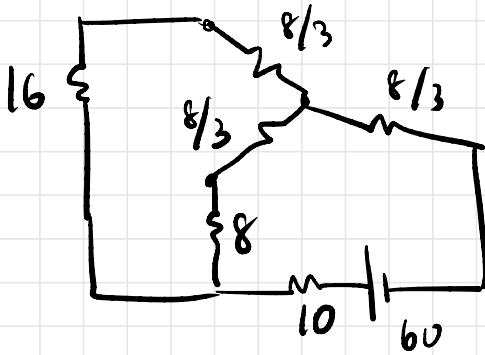

$$R_{eq} = 19.45$$

$$= \frac{214}{11}$$

$$I = \frac{330}{107} = 3.08$$

$$V_{10} = 30.84V$$

Q18.

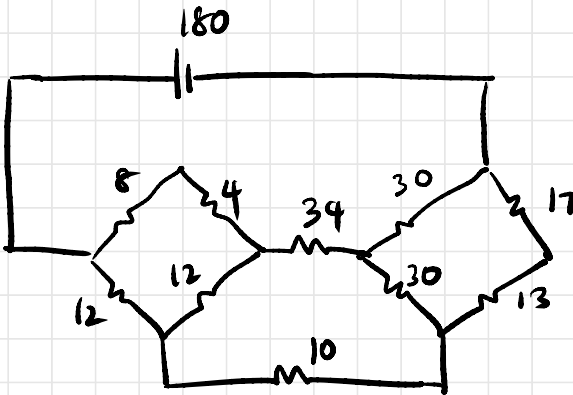

$$I_{10\Omega} = ?$$

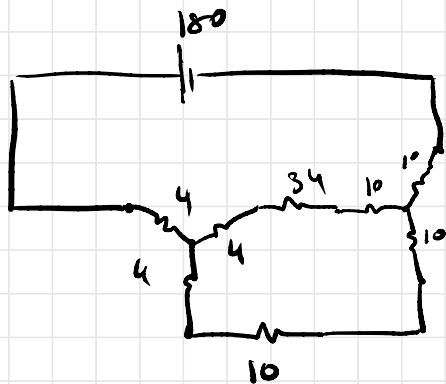
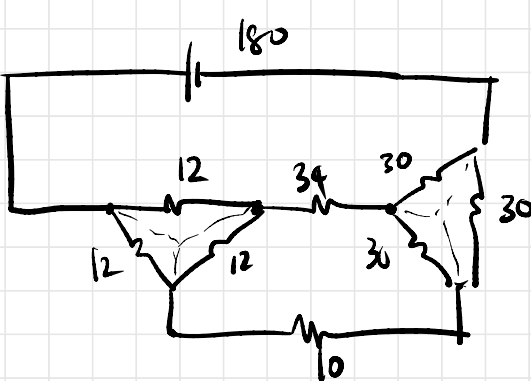

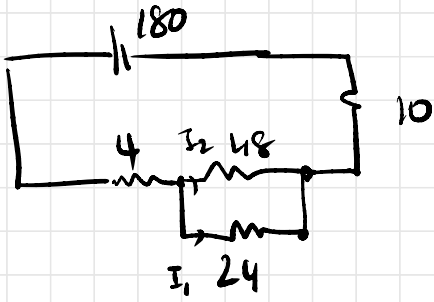

$$R_{eq} = 30 \Omega$$

$$I = 6 \text{ A}$$

CDR:

$$I_1 = \frac{48}{72} \times 6 = 4 \text{ A}$$

$$I_{10\Omega} = 4 \text{ A}$$

13.01.2020

Q19

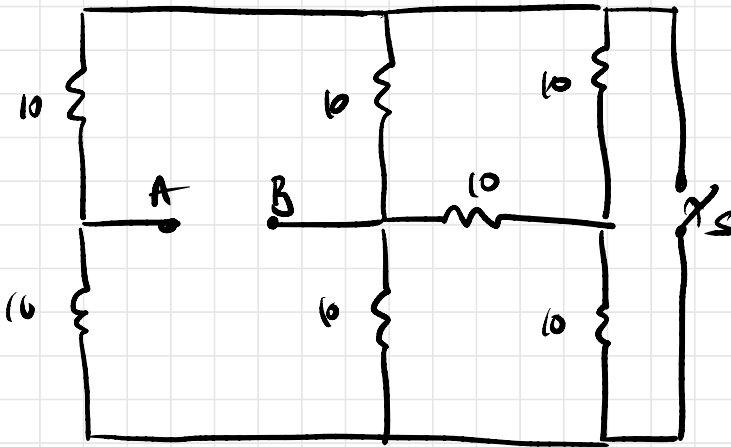

- (i) S closed
- (ii) S open

(i)

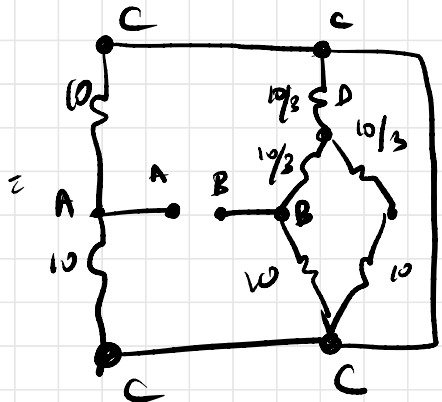
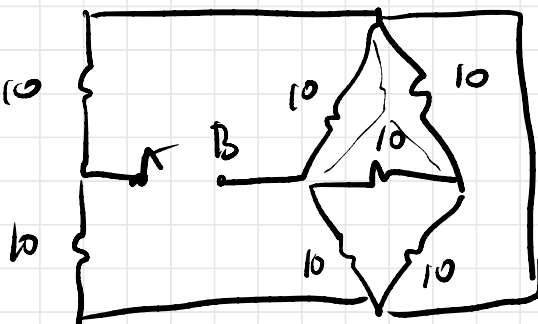

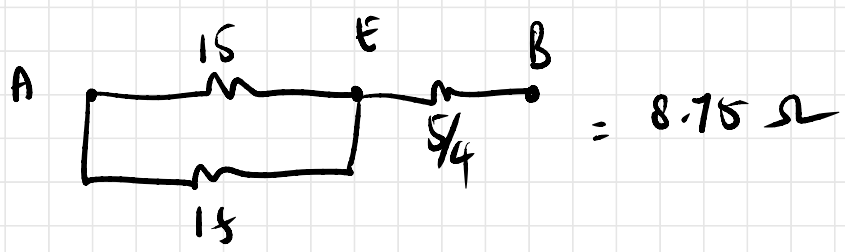
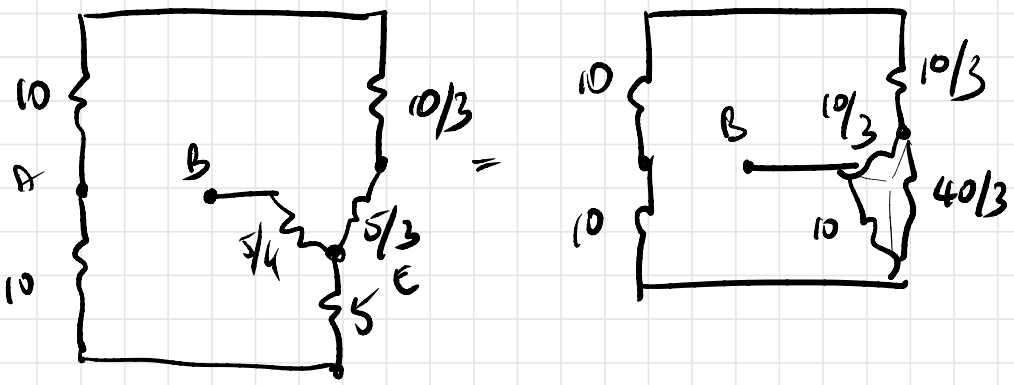
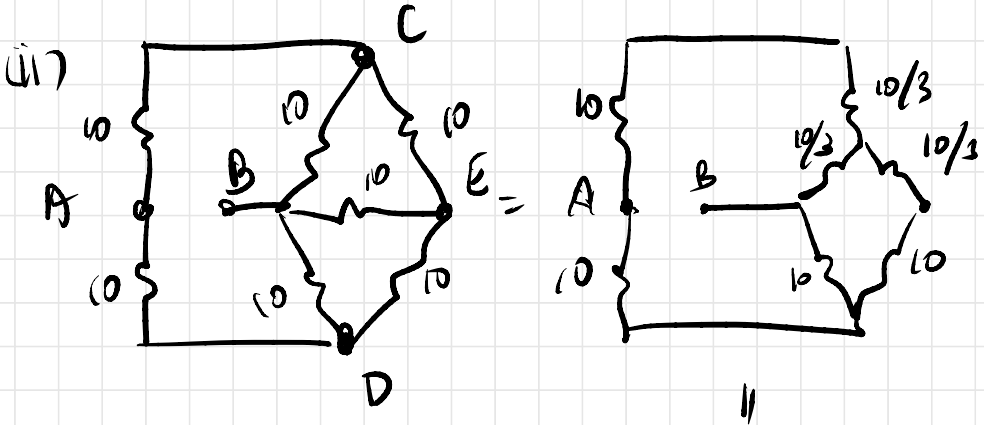
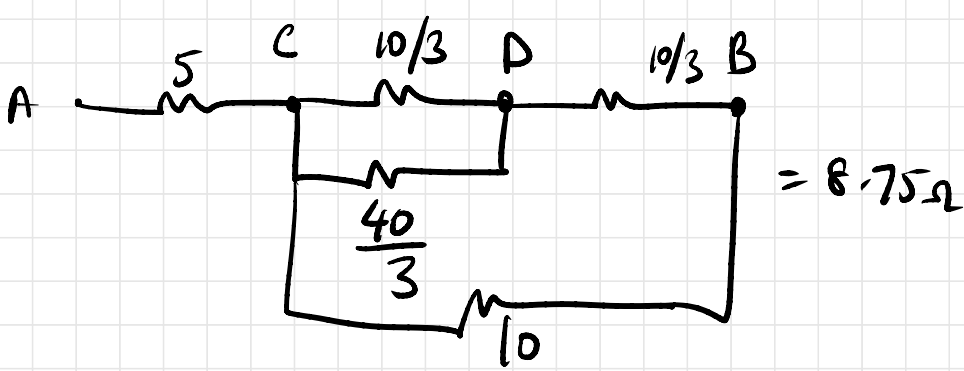

820.

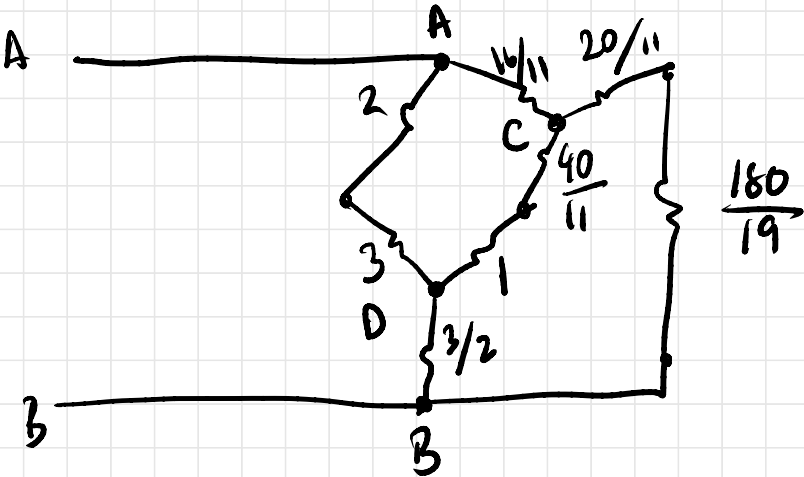
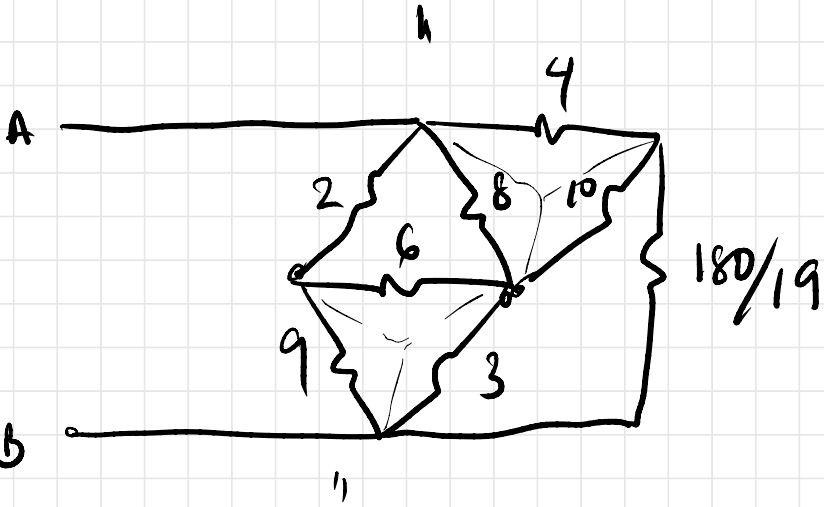
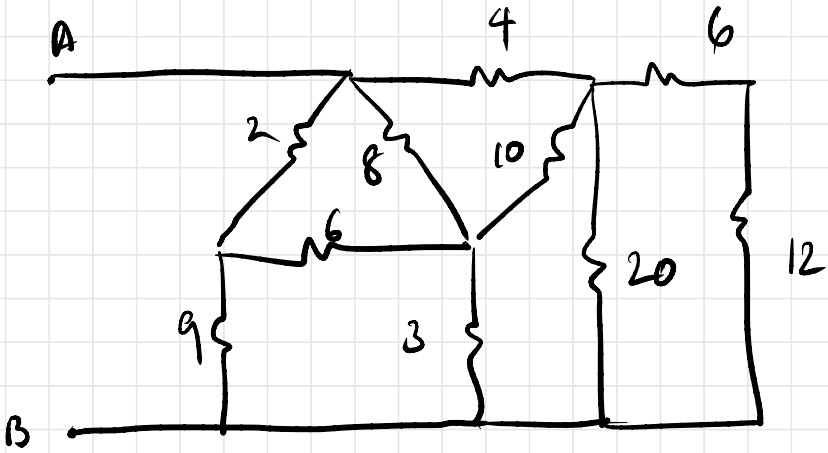

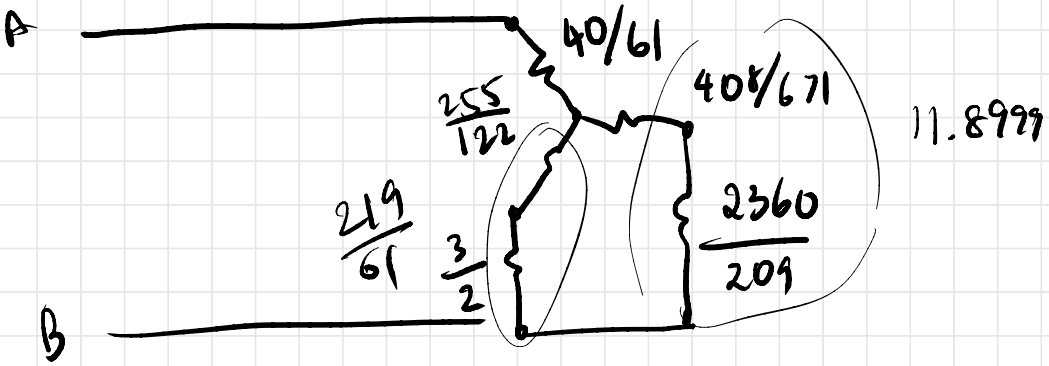
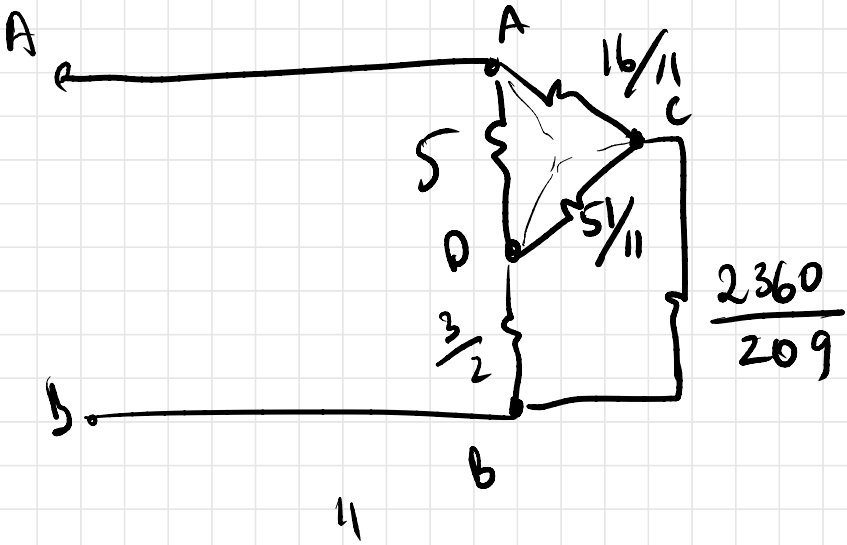

$$R_{AB} = 3.41 \Omega$$

KIRCHHOFF'S LAWS

1) KVL

algebraic sum of emfs and voltage drops in a closed circuit loop is always 0.

2) KCL

current entering junction = current exiting junction

Q21. By using Kirchhoff's Laws, find I_{xy} for the given circuit.

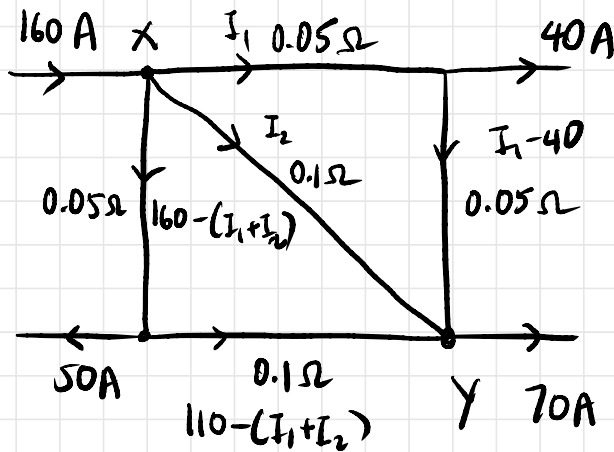

loop 1

$$0.1(110 - I_1 - I_2) + 0.05(160 - I_1 - I_2) - 0.1I_2 = 0$$

$$220 - 2I_1 - 2I_2 + 160 - I_1 - I_2 - 2I_2 = 0$$

$$5I_2 + 3I_1 = 380 \longrightarrow (1)$$

loop 2

$$-0.05 I_1 - 0.05(I_1 + 40) + 0.1 I_2 = 0$$

$$-I_1 - I_1 + 40 + 2I_2 = 0$$

$$2I_1 - 2I_2 = 40$$

$$I_1 = 20 + I_2 \longrightarrow (2)$$

(1) and (2)

$$5I_2 + 3(20 + I_2) = 380$$

$$8I_2 = 320$$

$$I_2 = 40 \text{ A}$$

$$I_1 = 60 \text{ A}$$

$$\boxed{I_{xy} = 40 \text{ A}}$$

don't make
silly mistakes
!!!

Q24.

current exiting source must enter source

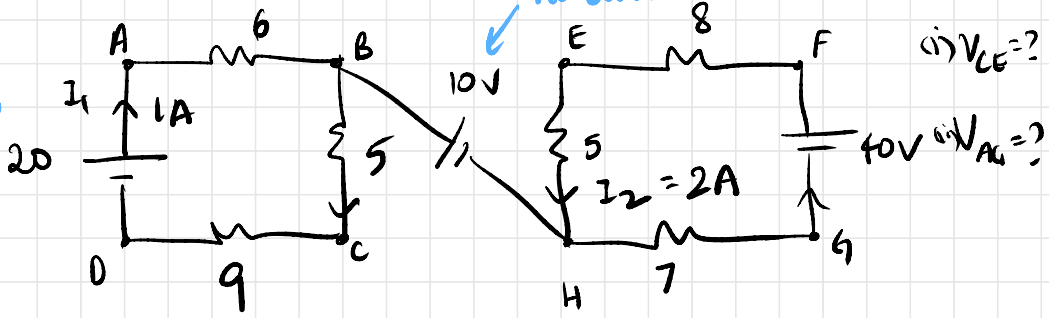

$$V_{CE} = -5(2) + 10 - 5 = -5V$$

$$V_{AG} = 14 + 10 + 6 = 30V$$

MESH CURRENT ANALYSIS

Assume current in each mesh, not branch

Q22.

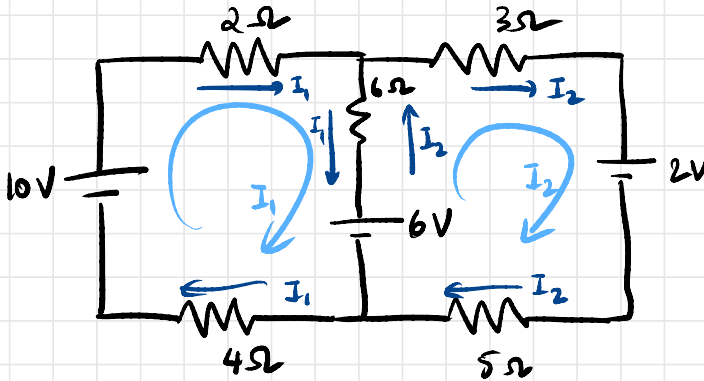

Find current through 6Ω

KVL: I_1 dominating

$$-6 + 10 - 2I_1 + 6(I_2 - I_1) - 4I_1 = 0$$

$$4 + 6I_2 - 12I_1 = 0 \rightarrow (1)$$

I_2 dominating

$$6 + 6(I_1 - I_2) - 3I_2 - 2 - 5I_2 = 0$$

$$4 + 6I_1 - 14I_2 = 0 \rightarrow (2)$$

$$I_1 = \frac{20}{33} \quad I_2 = \frac{6}{11}$$

$$I_{6\Omega} = 0.06 \text{ A}$$

Q23. Find power delivered to 16Ω using mesh analysis

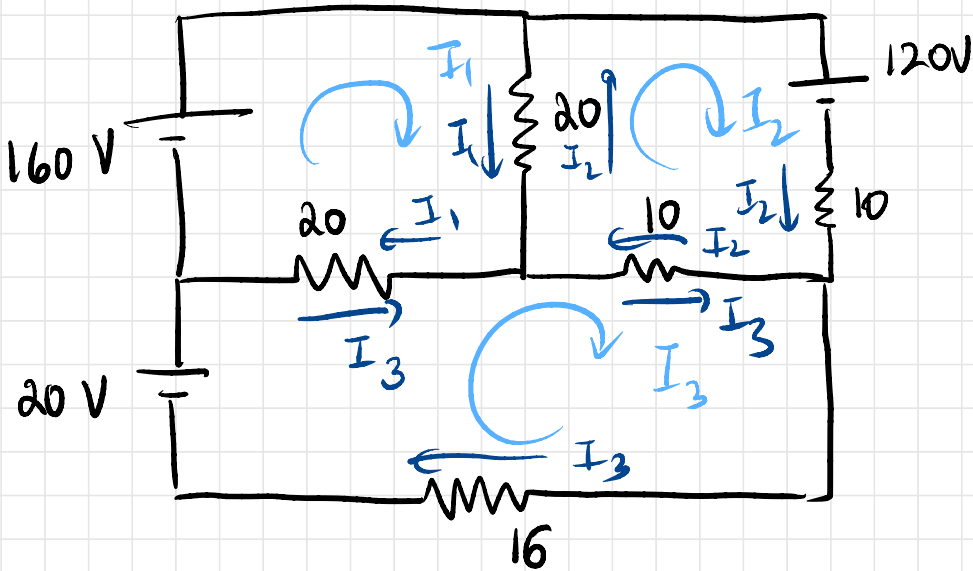

$$160 - (I_1 - I_2)(20) - (I_1 - I_3)(20) = 0$$

$$160 - 20I_1 + 20I_2 - 20I_1 + 20I_3 = 0$$

$$160 - 40I_1 + 20I_2 + 20I_3 = 0$$

$$8 - 2I_1 + I_2 + I_3 = 0 \rightarrow (1)$$

$$-120 - 10I_2 - 10(I_2 - I_3) - 20(I_2 - I_1) = 0$$

$$-12 - 4I_2 + I_3 + 2I_1 = 0 \rightarrow (2)$$

$$-16(I_3) + 20 - 20(I_3 - I_1) - 10(I_3 - I_2) = 0$$

$$-46I_3 + 20 + 20I_1 + 10I_2 = 0$$

$$I_1 = 6.029$$

$$I_2 = 0.823$$

$$I_3 = 3.235$$

$$\text{Power} = I^2 R = \left(\frac{55}{17}\right)^2 \times 16$$

$$\text{Power} = 167 \text{ W}$$

Q24.

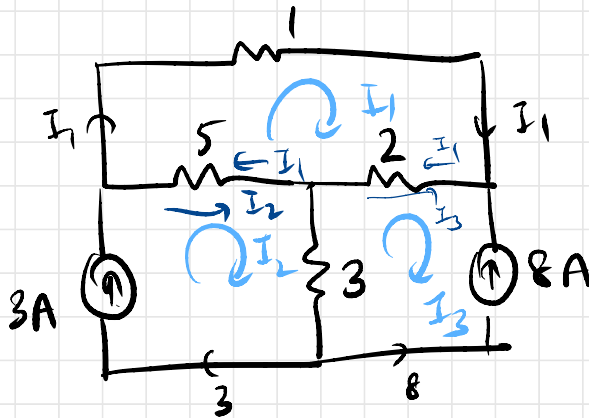

KCL:

$$I_2 - I_3 = 11 \rightarrow (1)$$

$$8 = -I_1 + I_1 - I_3 \rightarrow (2)$$

$$I_3 = -8 \text{ A}$$

$$I_2 = 3 \text{ A}$$

KVL in loop 1:

$$-I_1 - 2(I_1 - I_3) - 5(I_1 - I_2) = 0$$

$$-I_1 - 2I_1 + 2(-8) - 5I_1 + 5(3) = 0$$

$$-8I_1 = 1 \Rightarrow I_1 = -0.125$$

$$I_{5\Omega} = -3.125 \text{ A}$$

Q25.

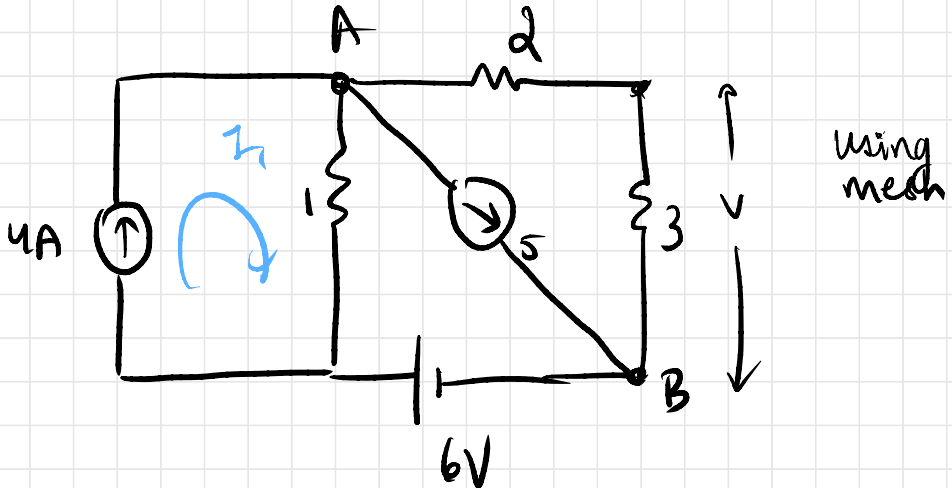

cannot assume meshes with common source

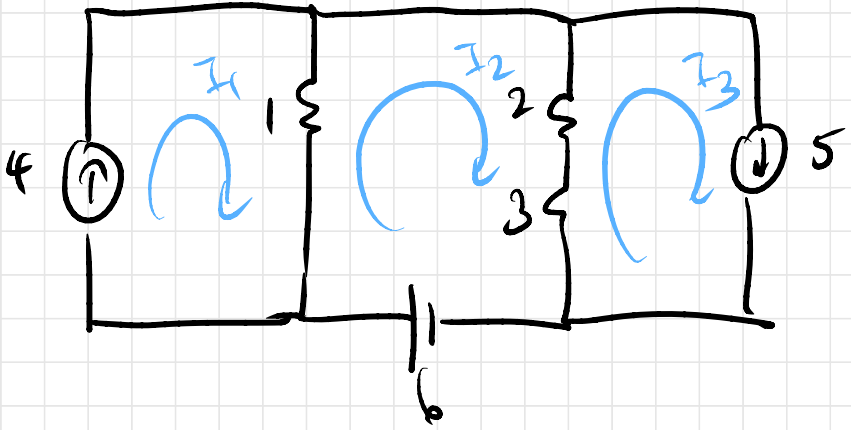

$$I_1 = 4A, I_3 = 5A$$

$$6 - (I_2 - I_1) - 5(I_2 - I_3) = 0$$

$$6 - 6I_2 + 4 + 25 = 0$$

$$I_2 = \frac{35}{6}$$

$$V_{3\Omega} = 3(I_2 - I_3) = 2.5V$$

Superposition Theorem

To find the effect of multiple sources, we find the effect of each individual source, one at a time and add them up to find the total response of the multiple sources.

We neglect the other sources by replacing them with their internal resistances.

Voltage sources are short-circuited and current sources are opened

The response of a linear network containing multiple sources of emf can be calculated by summing the effect of each source considered separately while all other sources are replaced by their internal resistances.

Q26. Find $I_{3\Omega}$ using superposition theorem

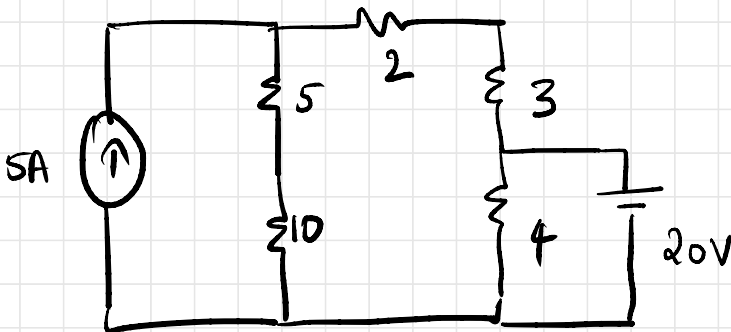

response due to current source

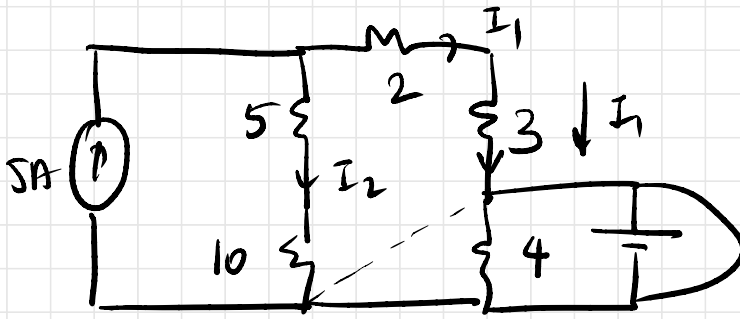

current division rule

$$I_1 = \frac{5(15)}{15+5} = \frac{5 \times 15}{20} = 3.75 \text{ A down}$$

response due to voltage source

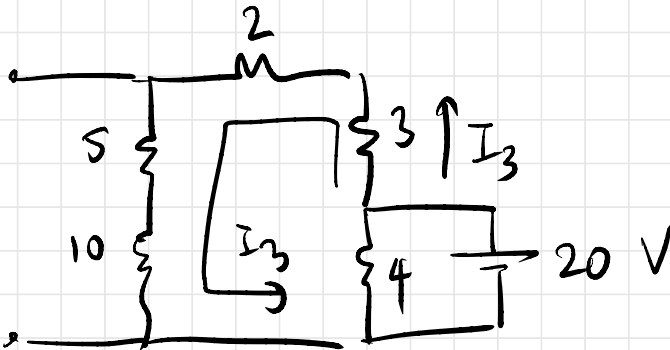

$$I_3 = \frac{20}{3+2+5+10} = \frac{20}{20} = 1 \text{ A up}$$

$$\therefore I_{3\Omega} = I_1 - I_3 = 2.75 \text{ A downwards}$$

927.

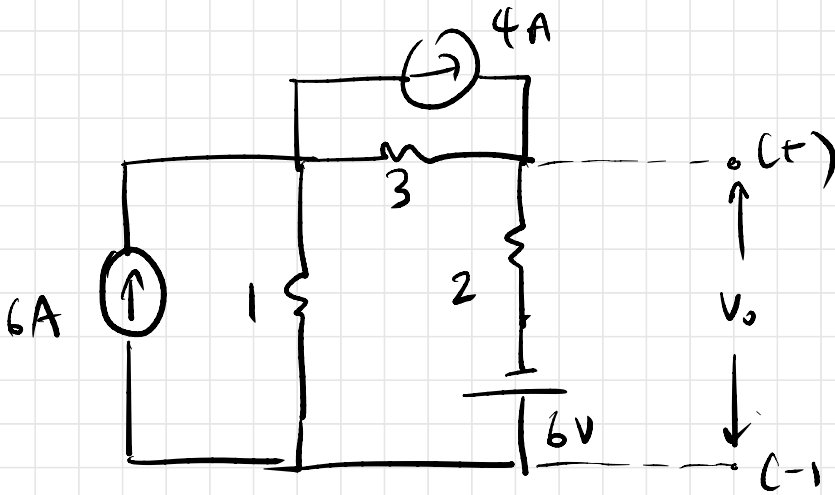

effect of 6A:

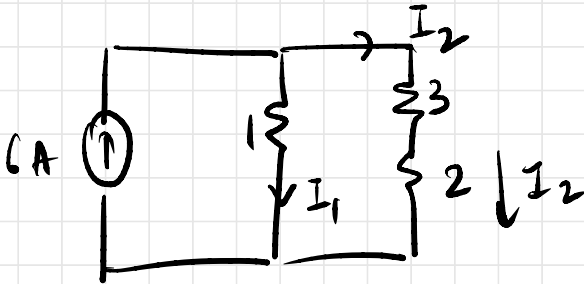

$$I_2 = \frac{(6)(1)}{6} = 1 \text{ A down}$$

effect of 4A:

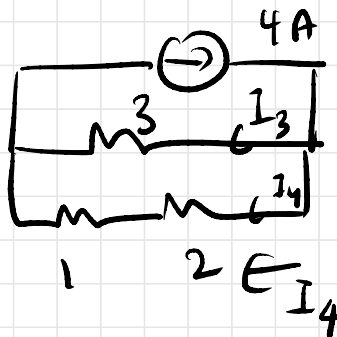

$$I_4 = \frac{(4)(3)}{(6)} = 2 \text{ A down}$$

effect of 6V

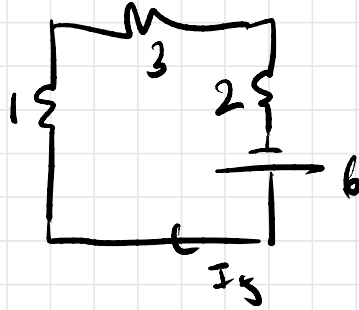

$$I_5 = \frac{6}{6} = 1 \text{ A}$$

$$I_{2a} = I_2 + I_4 + I_5 = 4 \text{ A down}$$

$$V_o = -6 + 2(4) = 2 \text{ V}$$

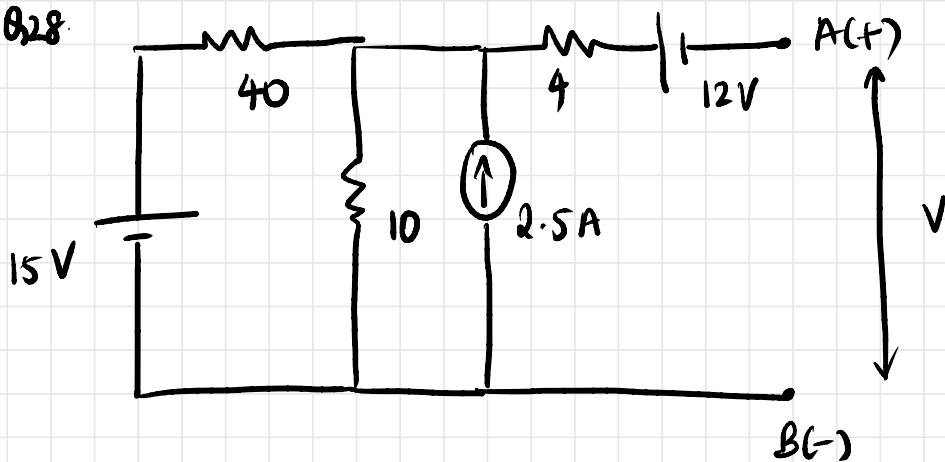

effect of 15 V

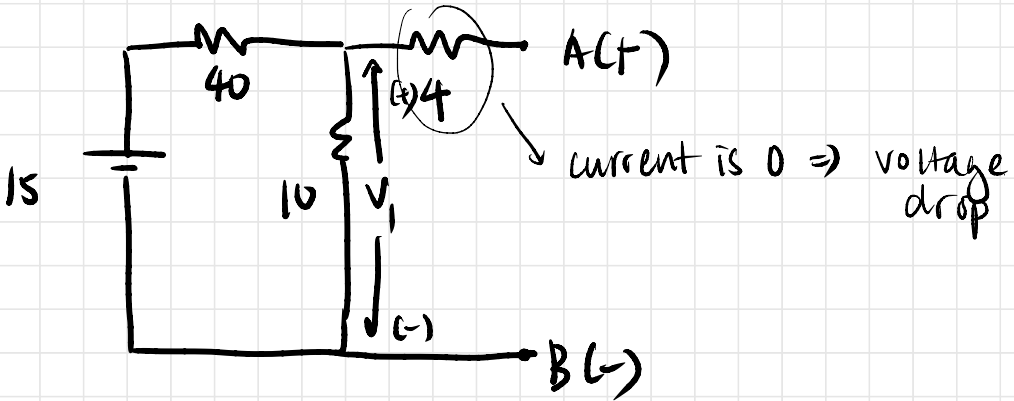

voltage division rule

$$V_1 = \frac{(15)(10)}{(40+10)} = 3V$$

effect of 2.5 A

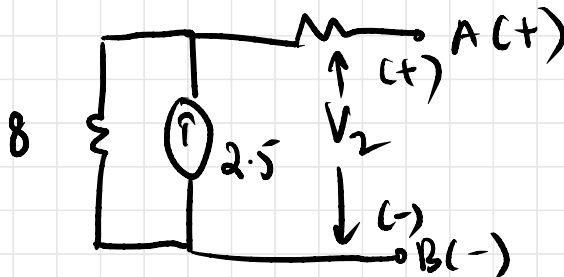
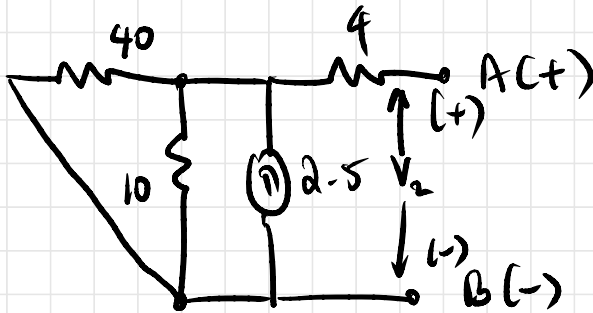

$$V_2 = 20V$$

effect of 12 V

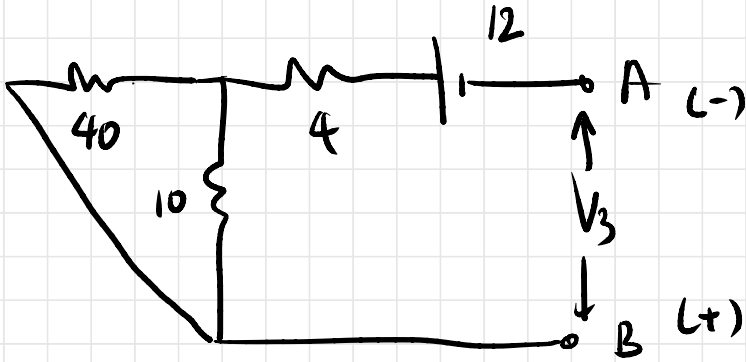

$$V_3 = -12V$$

$$V = 3 + 20 - 12 = 11V$$

Thevenin's Theorem

It is possible to simplify any linear circuit/network containing dependent or independent sources no matter how complex it is to an equivalent circuit with just a single voltage source and series resistance between any two points on the circuit.

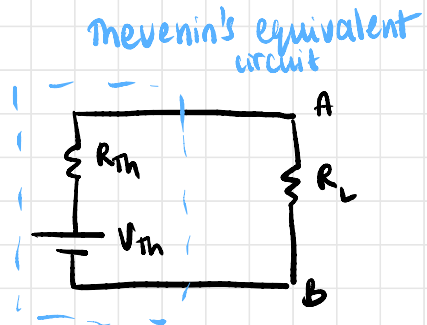
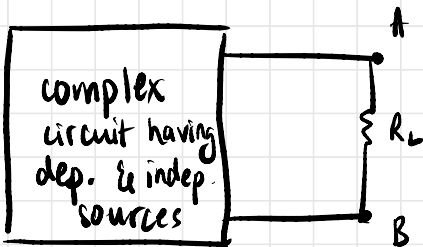

V_{Th} : temporarily remove R_L and find open circuit voltage across load R_L

R_{Th} : replace all sources by internal resistances (shorted V sources and open I sources). Find resistance across A and B.

Q29. Using Thevenin's Theorem, calculate PD across A B

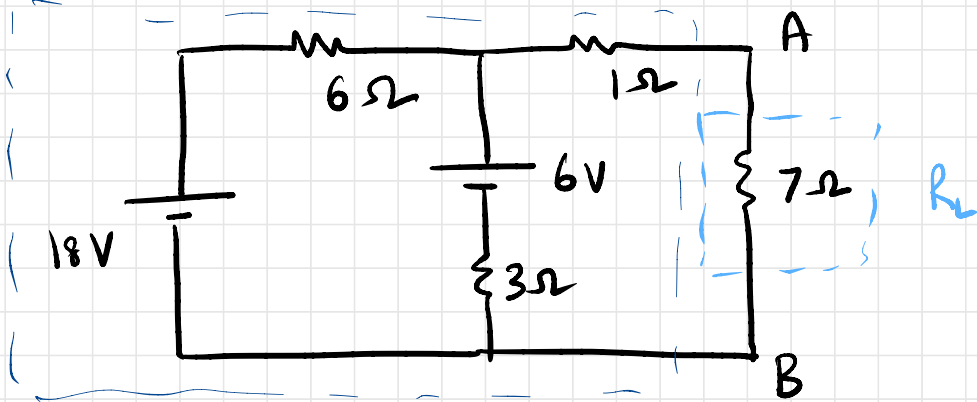

To find V_{Th}

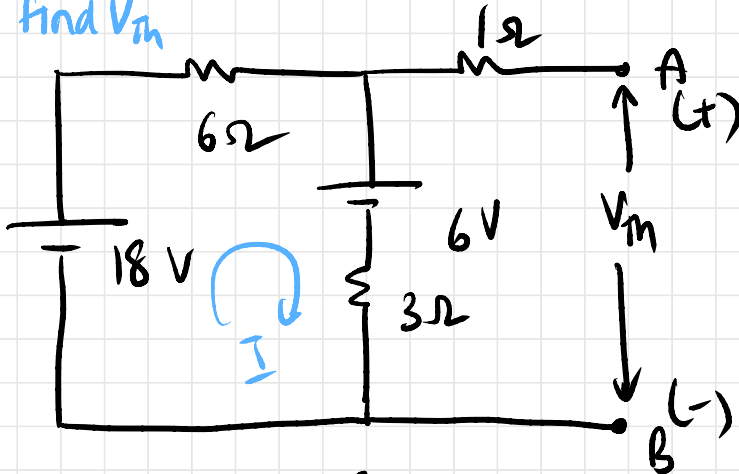

$$KVL: 18 - 6I - 6 - 3I = 0$$
$$9I = 12 \Rightarrow I = 1.33A$$

$$\text{KVL: } V_{AB} = (3 \times \frac{4}{3}) + 6 = 10\text{V} = V_{Th}$$

$$V_{Th} = 10\text{V}$$

To find R_L

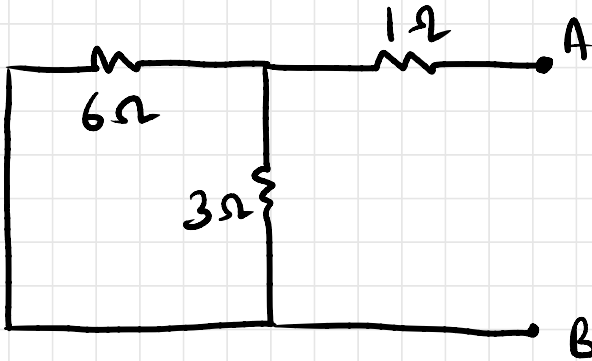

$$R_{Th} = 2 + 1$$

$$R_{Th} = 3\Omega$$

Thevenin's equivalent circuit

draw this circuit!

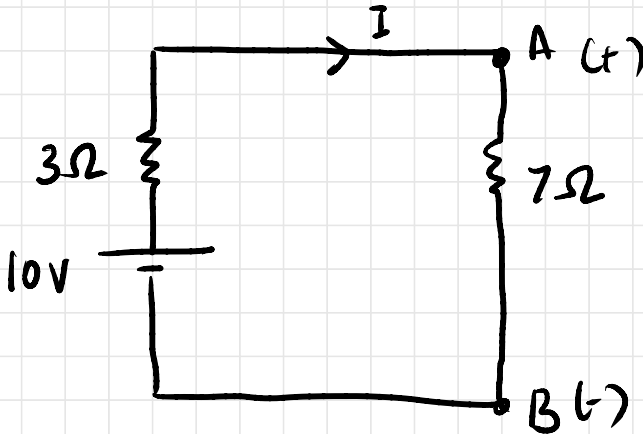

$$I = \frac{10\text{V}}{10\Omega} = 1\text{A}$$

$$V_{AB} = 7\text{V}$$

Q30.

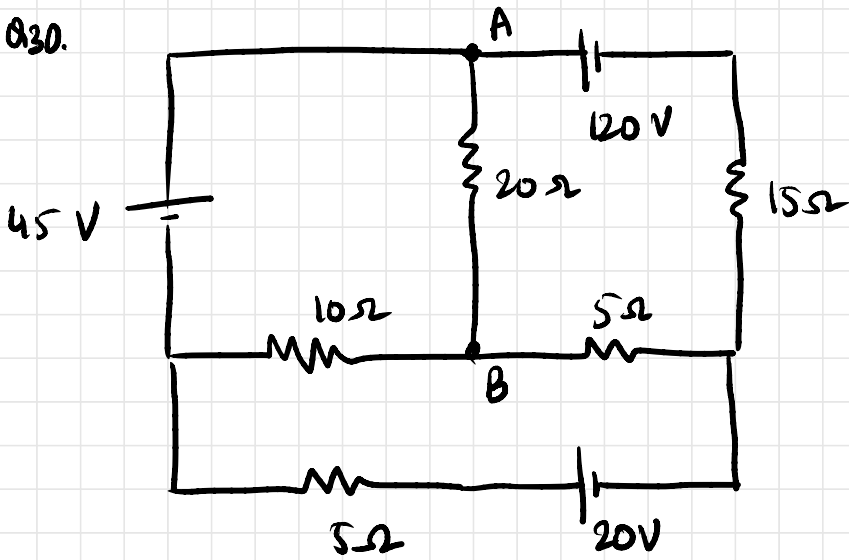

Find $I_{20\Omega}$

To find V_{Th}

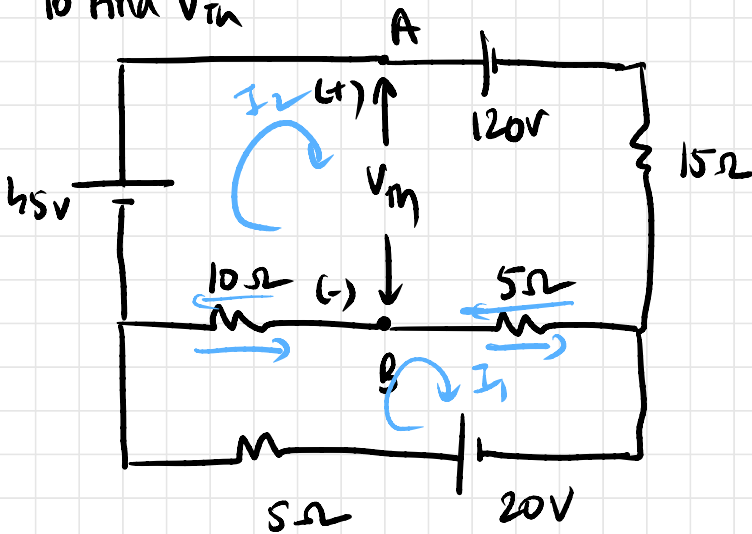

Mesh 1:

$$45 - 120 - 15I_2 - 5(I_2 - I_1) - 10(I_2 - I_1) = 0$$

$$-75 - 30I_2 + 15I_1 = 0$$

$$-5 - 2I_2 + I_1 = 0 \rightarrow (1)$$

Meth 2:

$$20 - 5I_1 - 10(I_1 - I_2) - 5(I_1 - I_2) = 0$$

$$20 - 20I_1 + 15I_2 = 0$$

$$4 - 4I_1 + 3I_2 = 0 \rightarrow (2)$$

$$I_1 = -\frac{1}{5} \text{ A}$$

$$I_2 = \frac{16}{5} \text{ A}$$

$$V_{th} = + I_2 5 - I_1 5 + 15I_2 + 120$$

$$= 20 \left(\frac{16}{5} \right) + 7 + 120$$

$$= 63$$

To find R_{th}

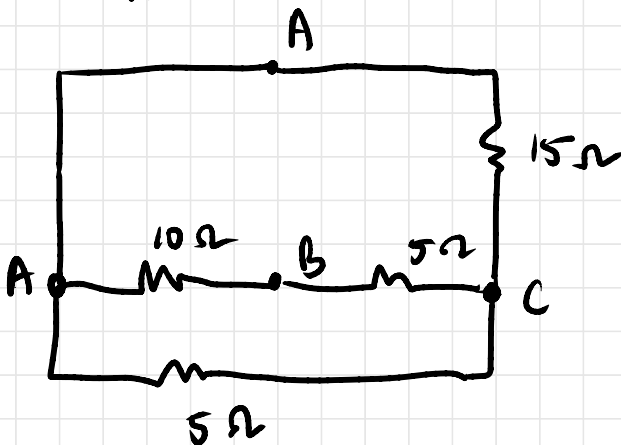

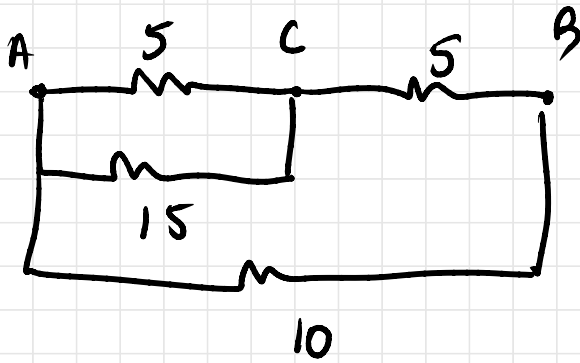

$$R_{Th} = \frac{14}{3} = 4.67 \Omega$$

equivalent circuit

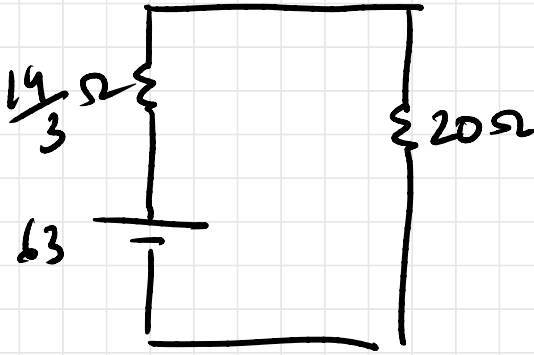

$$I_{20\Omega} = \frac{63}{20 + \frac{14}{3}}$$

$$I_{20\Omega} = 2.55 \text{ A}$$

Q31. Obtain Thevenin's equivalent between x & y.

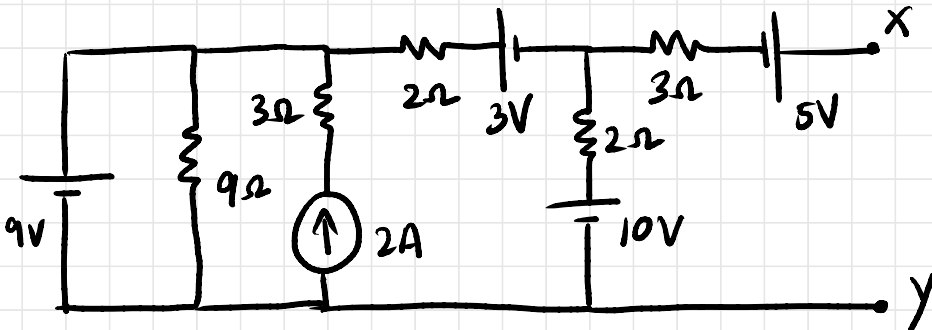

V_m : Superposition Theorem

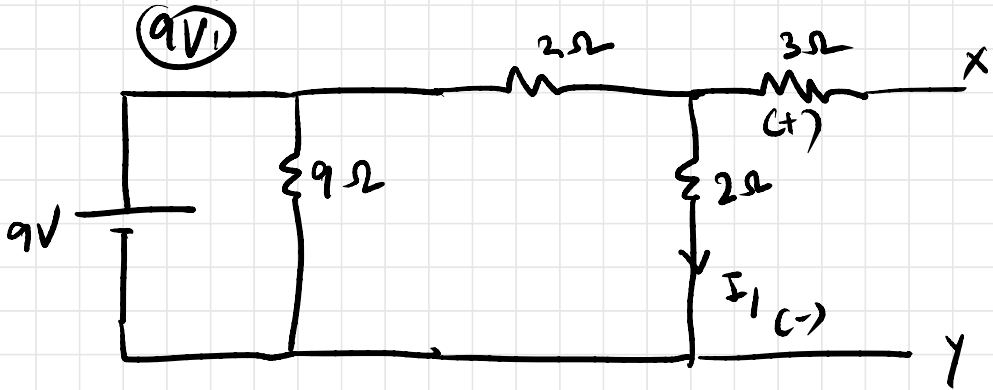

$$I_1 = \frac{9}{4} = 2.25 \text{ A}$$

$$V_{XY_1} = 4.5 \text{ V} \rightarrow (1)$$

(2A)

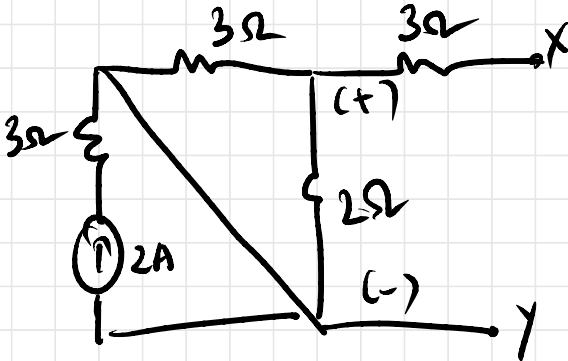

$$V_{XY_2} = 0$$

(3V)

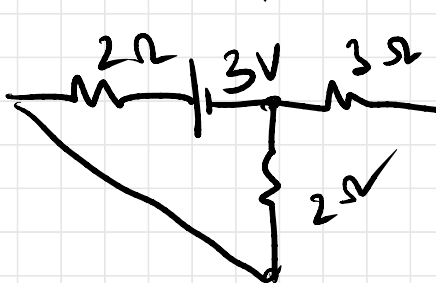

$$V_{XY_3} = -1.5$$

(10V)

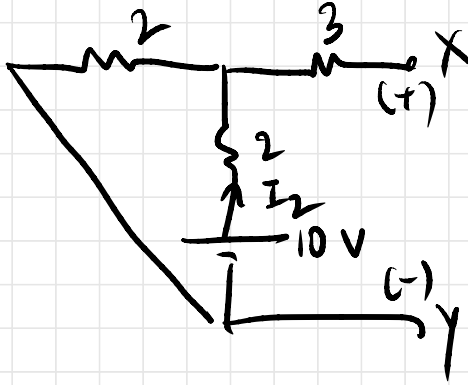

$$I_2 = \frac{10}{4} = 2.5$$

$$V_{xy3} = 10 - 5$$

$$V_{xy3} = 5V$$

(5V)

$$V_{xy4} = 5V$$

$$V_{th} = 13V$$

R_{th} :

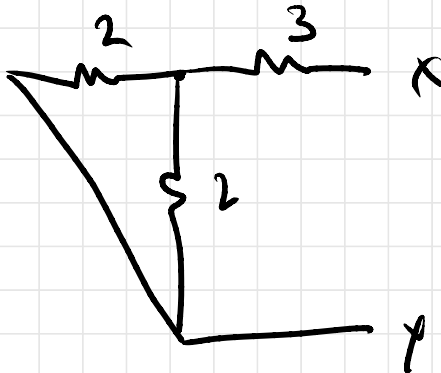

$$R_{th} = 4A$$

Q32. Find Thevenin's equivalent b/w A & B.

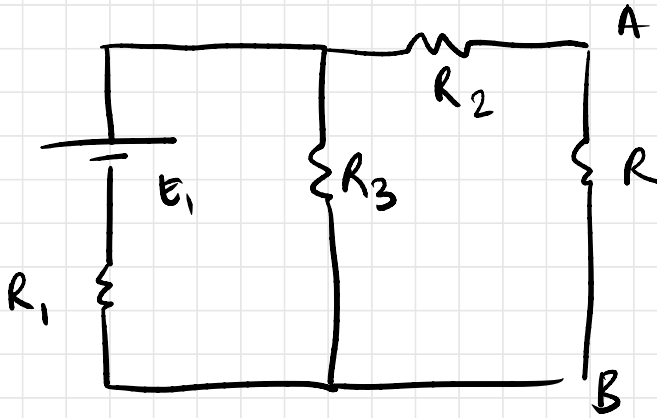

V_{Th} :

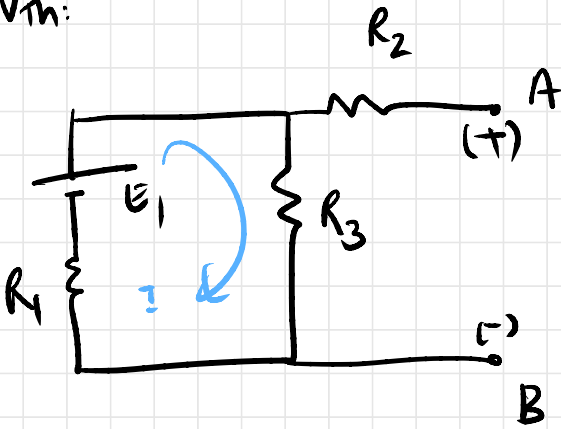

$$I = \frac{E_1}{R_1 + R_3}$$

$$V_{Th} = \frac{E_1 R_3}{R_1 + R_3}$$

R_{Th}

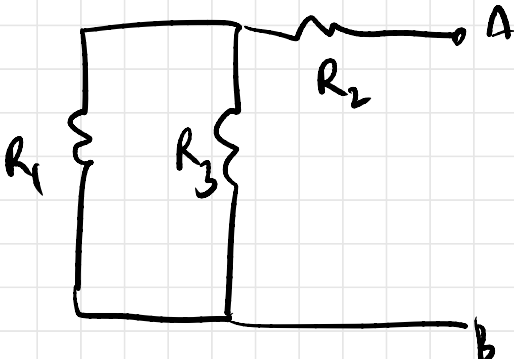

$$R_{Th} = \frac{R_1 R_3}{R_1 + R_3} + R_2$$

Thévenin's equivalent circuit

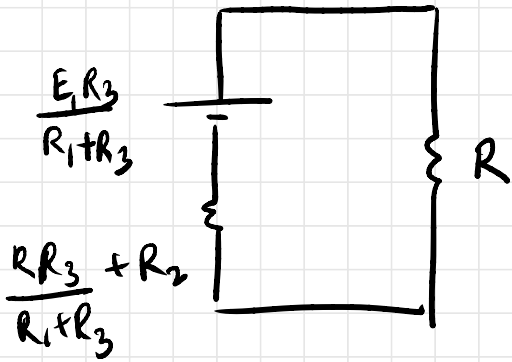

Q33. Find I_{BD}

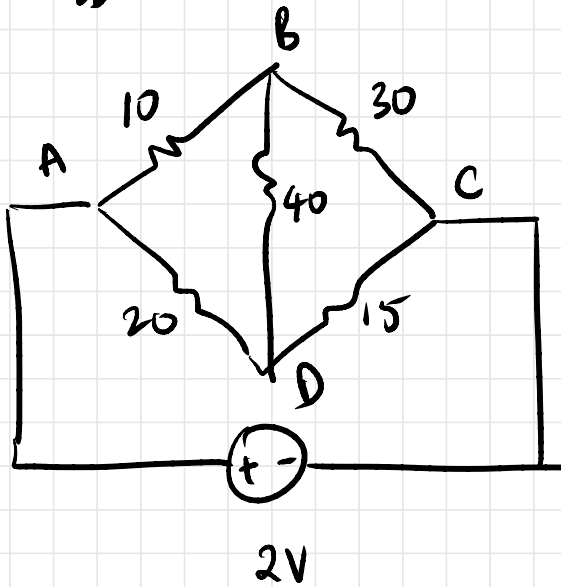

V_m

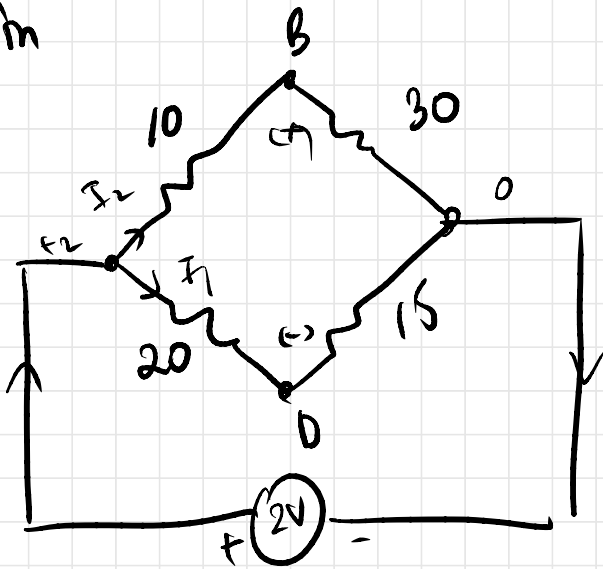

$$I_1 = \frac{I(40)}{(40+35)}$$

$$I = \frac{2 \times 3}{56} = \frac{3}{28}$$

$$I_1 = \frac{2}{35} = 0.057 \text{ A}$$

$$I_2 = \frac{1}{20} = 0.05 \text{ A}$$

$$V_B = 2 - \frac{10}{20} = 1.5$$

$$V_0 = 2 - \frac{20 \times 2}{35} = \frac{6}{7} = 0.857 \text{ V}$$

$$V_m = \frac{9}{14} = 0.64 \text{ V}$$

R_m

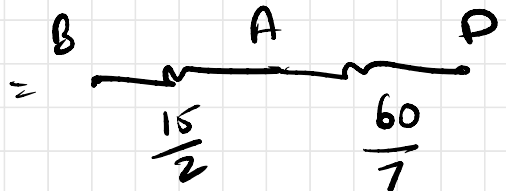
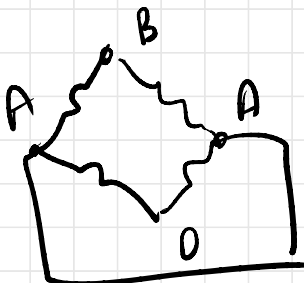

$$R_m = \frac{225}{14} = 16.07$$

Wwwit

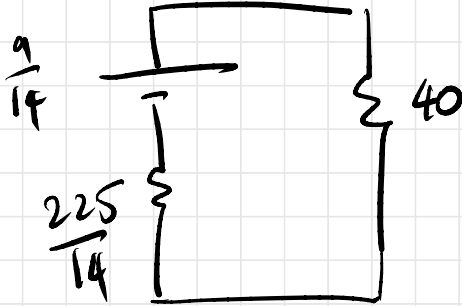

$$I = \frac{9}{785} = 11.46 \text{ mA}$$